

1.1 - POWER TILT MODULES

- POWER TILT (STD & HD), FRONT ACTUATOR, SAE 1.1.1
- POWER TILT (STD & HD), FRONT ACTUATOR, METRIC 1.1.2
- POWER TILT (STD & HD), FRONT ACTUATOR, EBX 1.1.3
- POWER TILT (STD & HD), FRONT ACTUATOR, EBX, METRIC 1.1.4
- 50° POWER TILT, REAR ACTUATOR, SAE 1.1.5
- 50° POWER TILT, FRONT ANGLE ACTUATOR, SAE 1.1.6
- 45° POWER TILT VHD, 550 LB, FRONT ACTUATOR, SAE 1.1.7
- 45° POWER TILT VHD, 550 LB, FRONT ACTUATOR, METRIC 1.1.8

1.2 - POWER ELEVATE MODULES

- POWER SEAT ELEVATOR, 300 LB WEIGHT CAP 1.2.1
- POWER SEAT ELEVATOR, 300 LB WEIGHT CAP 1.2.2
- POWER SEAT ELEVATOR, 300 LB WEIGHT CAP CONNECTOR E-BX 1.2.3
- POWER SEAT ELEVATOR, 300 LB WEIGHT CAP CONNECTOR E-BX 1.2.4
- POWER SEAT ELEVATOR, 400 LB WEIGHT CAP 1.2.5
- POWER SEAT ELEVATOR, 400 LB WEIGHT CAP 1.2.6

1.4 - ASCENT POWER STANDING MODULE

- ASCENT POWER STANDING MODULE 1.4.1
- ANTI-TIP ASSEMBLY FOR ASCENT STANDING MODULE 1.4.2

1.5 - SHROUDS

- NO MODULE INSTALLATION 1.5.1
- TILT 1.5.2
- TILT 1.5.3
- ELEVATE 1.5.4
- COMBO 1.5.5

LEGEND

CURRENT

- These parts and assemblies are currently being produced and delivered.*

SERVICEABLE PARTS

- These parts and assemblies are not currently being produced or delivered on new chairs, but they are available as replacement service parts.*

DISCONTINUED

- These parts and assemblies are no longer being produced or delivered on new chairs, and they are not available as replacement service parts.*

* Please contact Technical Support for information on the replacement parts and assemblies.

POWER TILT (STD & HD), FRONT ACTUATOR, SAE			
ITEM #	PART #	DESCRIPTION	PRIOR TO
1A-8	C-6450	50° POWER TILT, FRONT ACTUATOR	2019-12-23
1B-8	S-0128	45° HD POWER TILT - FRONT ACTUATOR	2020-01-03
2,3,4	S-0152	MECHANICAL LIMIT SWITCH W/ HARDWARE	2020-02-03
5,6,7,8	S-0153	ACTUATOR, STROKE 127 MM 6000N W/ HARDWARE	2020-02-03

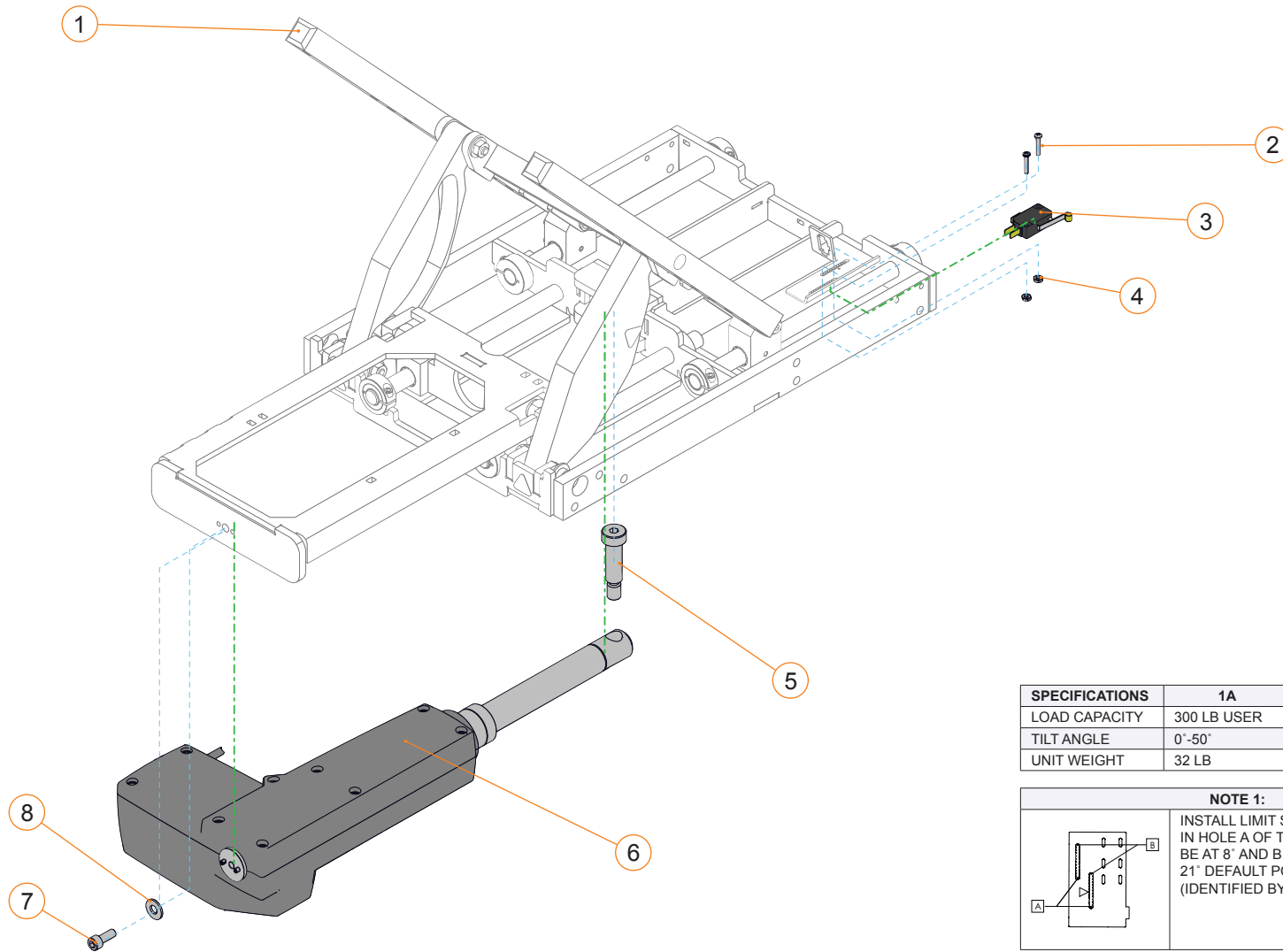

SPECIFICATIONS	1A	1B
LOAD CAPACITY	300 LB USER	450 LB USER
TILT ANGLE	0°-50°	0°-45°
UNIT WEIGHT	32 LB	33 LB

NOTE 1:

INSTALL LIMIT SWITCH #B00007 IN HOLE A OF THE SUPPORT TO BE AT 8" AND B TO BE AT 21" DEFAULT POSITION IS AT 15" (IDENTIFIED BY Δ)

POWER TILT MODULES - SECTION 1.1

POWER TILT (STD & HD), FRONT ACTUATOR, METRIC			
ITEM #	PART #	DESCRIPTION	PRIOR TO
1A-10	1001484	50° POWER TILT AND HARDWARE	2020-09-02
1B-10	1001482	45° HD POWER TILT AND HARWARE	2020-09-02
2,3,4	S-0152	MECHANICAL LIMIT SWITCH W/ HARDWARE	2021-05-03
5-7A,8-10	S-0153	ACTUATOR, STROKE 127 MM 6000N W/ HARDWARE	2022-12-15
ITEM #	PART #	DESCRIPTION	AFTER
5-7B,8-10	1004102	ACTUATOR, STROKE 127 MM 6000N W/ HARDWARE	2022-12-15

SPECIFICATIONS	1A	1B
LOAD CAPACITY	300 LB USER	450 LB USER
TILT ANGLE	0°-50°	0°-45°
UNIT WEIGHT	32 LB	33 LB

NOTE 1:

INSTALL LIMIT SWITCH #B00007 IN HOLE A OF THE SUPPORT TO BE AT 8° AND B TO BE AT 21° DEFAULT POSITION IS AT 15° (IDENTIFIED BY Δ)

POWER TILT MODULES - SECTION 1.1

POWER TILT (STD & HD), FRONT ACTUATOR, SAE, E-BX			
ITEM #	PART #	DESCRIPTION	EFFECTIVE
1A, 5-8	1001062	50° POWER TILT, FRONT ACTUATOR	2020-02-03
1A-8	S-0222	50° POWER TILT FOR SOLO / DUO / ISM	2020-02-03
1B, 5-8	1001063	45° HD POWER TILT	2020-02-03
2-4	S-0205	DRIVE LOCK-OUT SWITCH FOR TILT, E-BX	2020-02-03
5-8	S-0204	IQ ACTUATOR STD TILT, STROKE 127 MM 6000N	2020-02-03

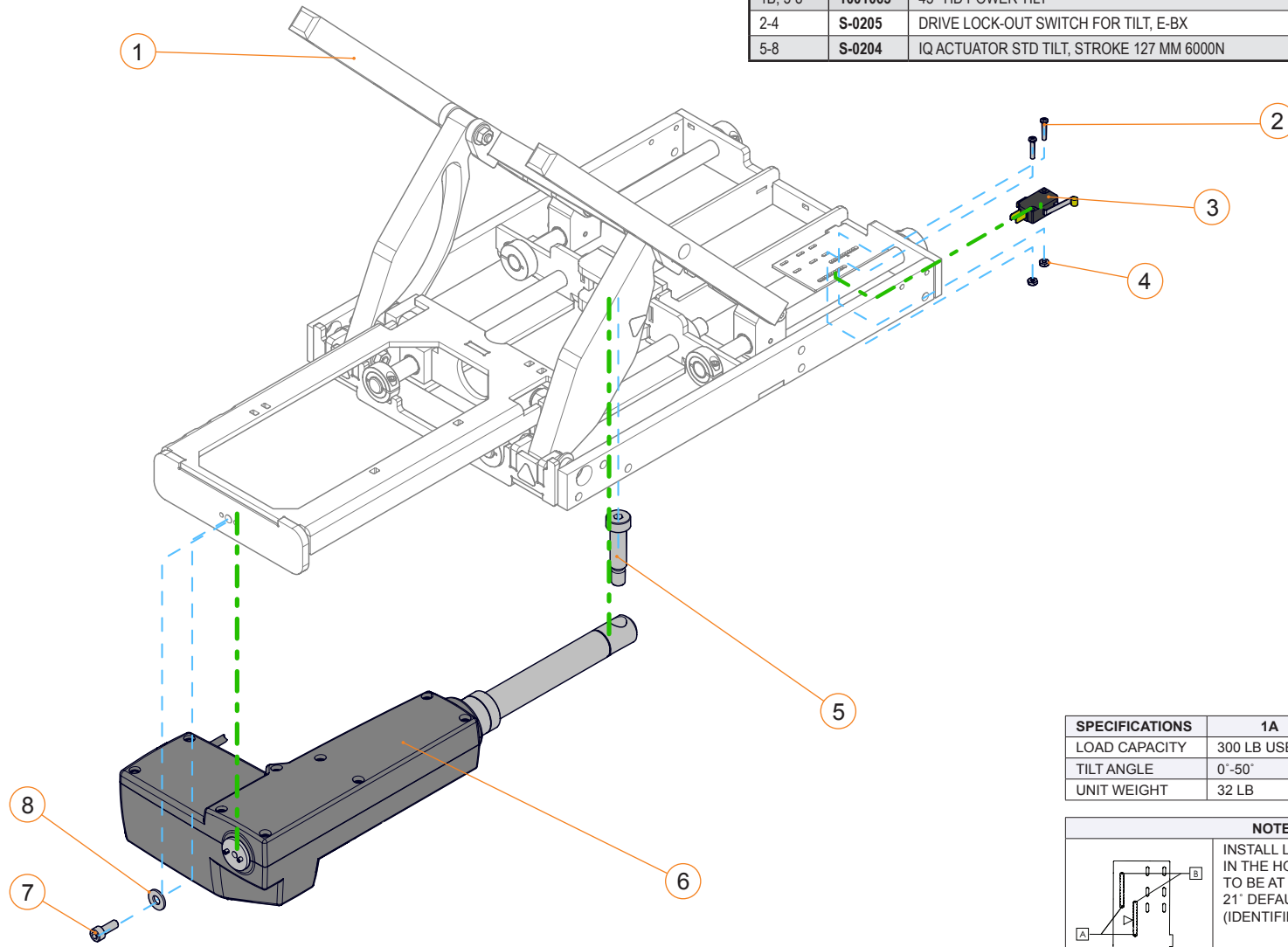

SPECIFICATIONS	1A	1B
LOAD CAPACITY	300 LB USER	450 LB USER
TILT ANGLE	0°-50°	0°-45°
UNIT WEIGHT	32 LB	33 LB

NOTE 1:

INSTALL LIMIT SWITCH 1000673 IN THE HOLE A OF THE SUPPORT TO BE AT 8" AND B TO BE AT 21" DEFAULT POSITION IS AT 15" (IDENTIFIED BY Δ)

POWER TILT MODULES - SECTION 1.1

POWER TILT (STD & HD), FRONT ACTUATOR, METRIC, E-BX			
ITEM #	PART #	DESCRIPTION	EFFECTIVE
1A, 5-10	1001448	50° POWER TILT AND HARDWARE, E-BOX	2020-09-02
1A-10	1001449	50° POWERTILT FRT ACT SOLO/DUO	2020-09-02
1B, 5-10	1001450	45 DEG HD POWER TILT AND HARDWARE, E-BOX	2020-09-02
2-4	S-0205	DRIVE LOCK-OUT SWITCH FOR TILT, E-BX	2021-05-03
5-10	S-0204	IQ ACTUATOR STD TILT, STROKE 127 MM 6000N	2021-05-03

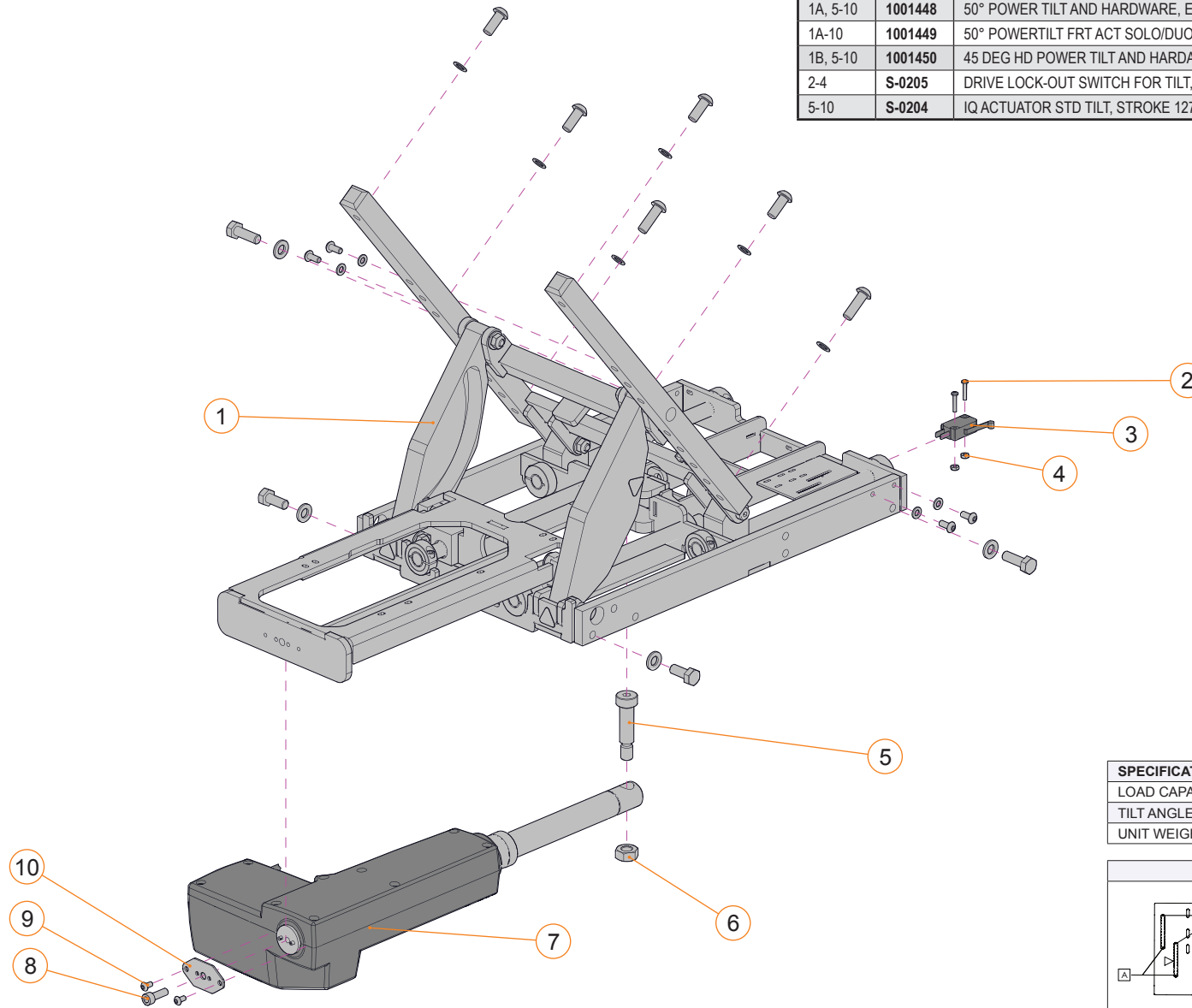

SPECIFICATIONS	1A	1B
LOAD CAPACITY	300 LB USER	450 LB USER
TILT ANGLE	0°-50°	0°-45°
UNIT WEIGHT	32 LB	33 LB

NOTE 1:

INSTALL LIMIT SWITCH 1000673 IN THE HOLE A OF THE SUPPORT TO BE AT 8" AND B TO BE AT 21" DEFAULT POSITION IS AT 15" (IDENTIFIED BY Δ)

50° POWER TILT, REAR ACTUATOR, SAE			
ITEM #	PART #	DESCRIPTION	PRIOR TO
1-7	C-5228	50° POWER TILT, REAR ACTUATOR, SAE	2011-08-02
2	E00187	HEX BOLT M12 X 35 MM	2011-08-02
3	R00032	ACTUATOR, STROKE 127 MM 6000N	2011-08-02
4	E00175	CAP SCREW M6 X 15 MM	2011-08-02
5	E00079	4-40 X 5/8 SCREW	2008-04-30
6	B00007	MECHANICAL LIMIT SWITCH	2008-04-30
7	E00349	4-40 NYLON INSERT LOCK NUT	2011-05-06

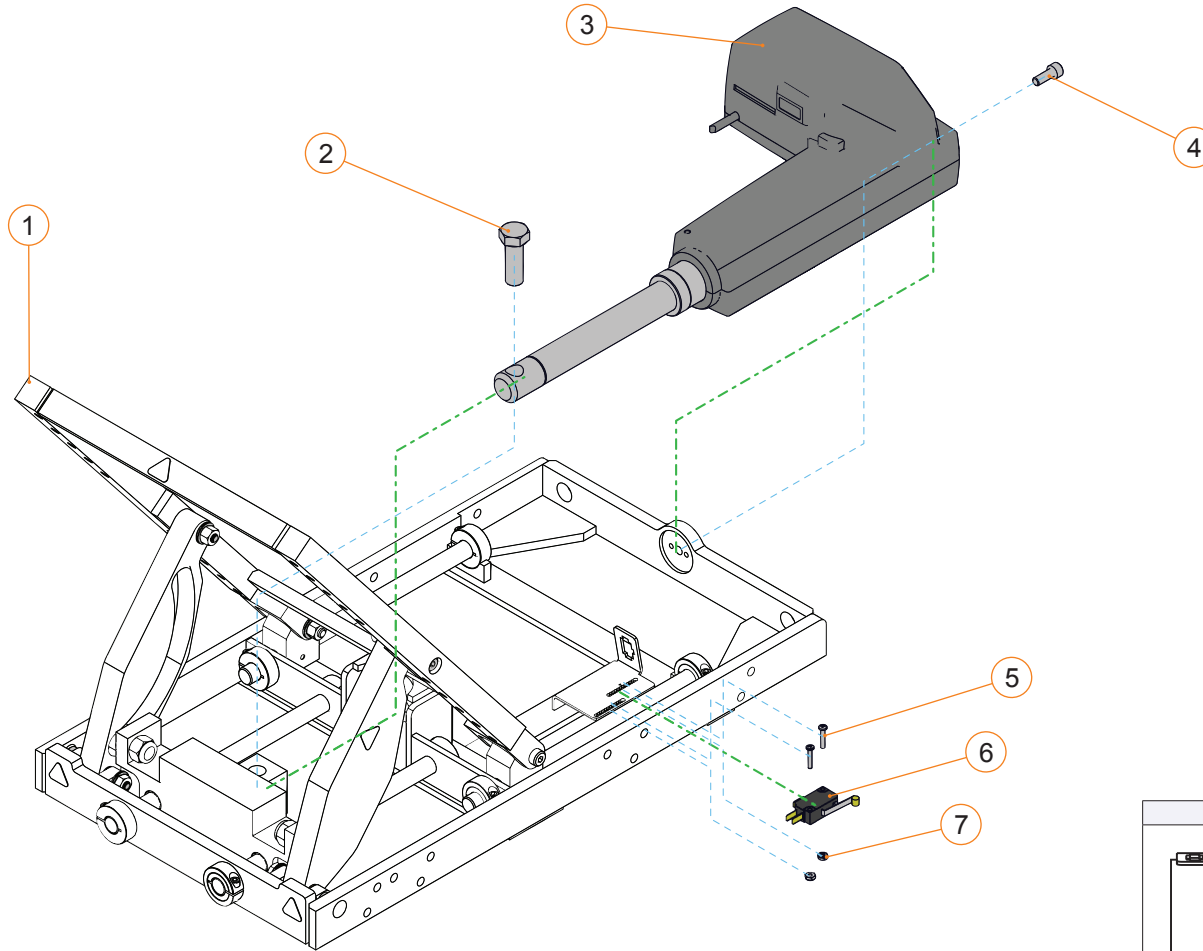

SPECIFICATIONS	
LOAD CAPACITY	400 LB USER
TILT ANGLE	0°-50°
UNIT WEIGHT	37 LB

NOTE 1:

INSTALL LIMIT SWITCH #B00007 IN THE POSITION "A" OF THE SUPPORT TO BE AT 8 IN AND B TO BE AT 21 IN. DEFAULT POSITION IS AT 15" (IDENTIFY WITH Δ).

50° POWER TILT, FRONT ANGLE ACTUATOR, SAE			
ITEM #	PART #	DESCRIPTION	PRIOR TO
2	E00079	4-40 X 5/8 SCREW	2008-04-30
3	B00007	MECHANICAL LIMIT SWITCH	2008-04-30
4	E00349	4-40 NYLON INSERT LOCK NUT	2011-05-06
5	E00076	M10 NYLON INSERT LOCK NUT	2008-04-30
6	E00039	3/8 IN FLAT WASHER	2008-04-30
7	R00042	ACTUATOR, STROKE 127 MM 6000N	2009-05-11
8	E00136	HEX BOLT M10 X 60 MM	2008-04-30
1-8	C-6009	50° POWER TILT, FRONT ANGLE ACTUATOR, SAE	2011-08-02

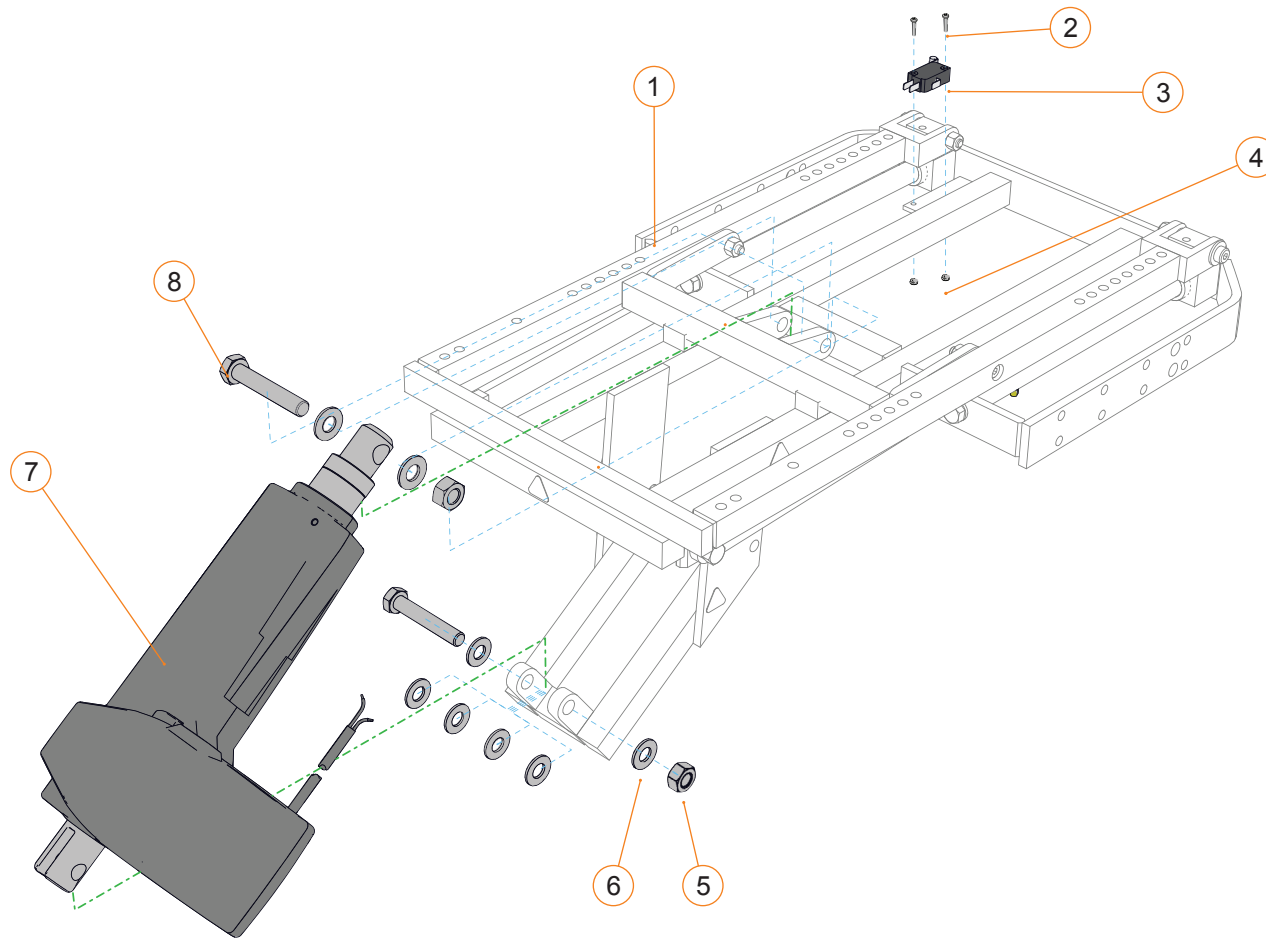

SPECIFICATIONS	
LOAD CAPACITY	400 LB USER
TILT ANGLE	0°-50°
UNIT WEIGHT	32 LB

POWER TILT MODULES - SECTION 1.1

45° POWER TILT VHD, 550 LB, FRONT ACTUATOR, SAE			
ITEM #	PART #	DESCRIPTION	EFFECTIVE
1-10	C-6503	45° POWER TILT, 550 LB, FRONT ACTUATOR, SAE	2010-04-22
2-4	1002491	KIT - DRIVE LOCK-OUT SWITCH	2020-11-16
5-10	1002492	KIT - VHD TILT ACTUATOR, 115MM - 8000N	2021-05-03

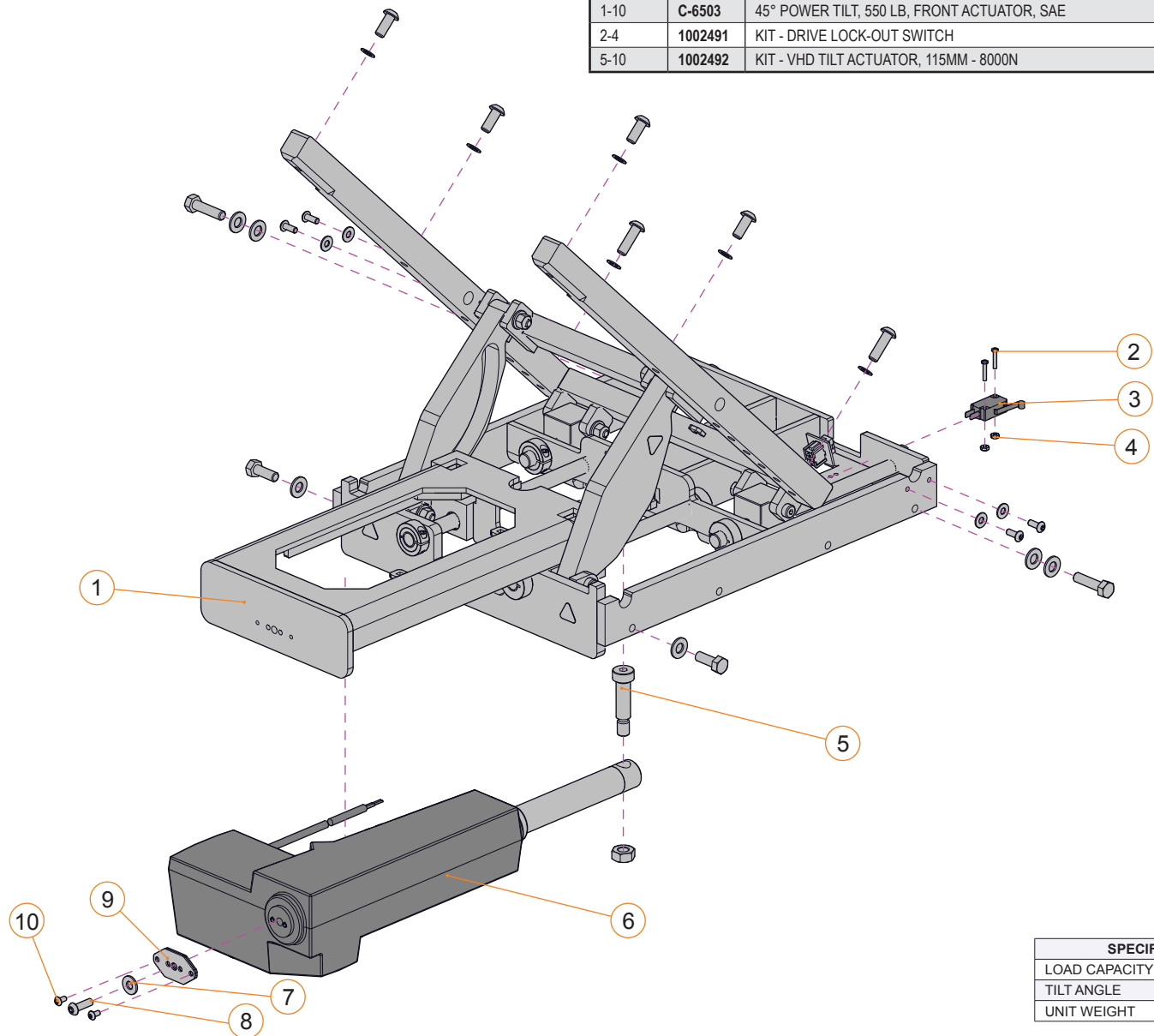

SPECIFICATIONS	
LOAD CAPACITY	550 LB USER
TILT ANGLE	0°-45°
UNIT WEIGHT	45 LB

POWER TILT MODULES - SECTION 1.1

45° POWER TILT VHD, 550 LB, FRONT ACTUATOR, METRIC			
ITEM #	PART #	DESCRIPTION	EFFECTIVE
1-10	1003878	45° POWER TILT AND HARDWARE, 550LBS, METRIC	2022-10-01
2-4	1002491	KIT - DRIVE LOCK-OUT SWITCH	2020-11-16
5-10	1002492	KIT - VHD TILT ACTUATOR, 115MM - 8000N	2021-05-03

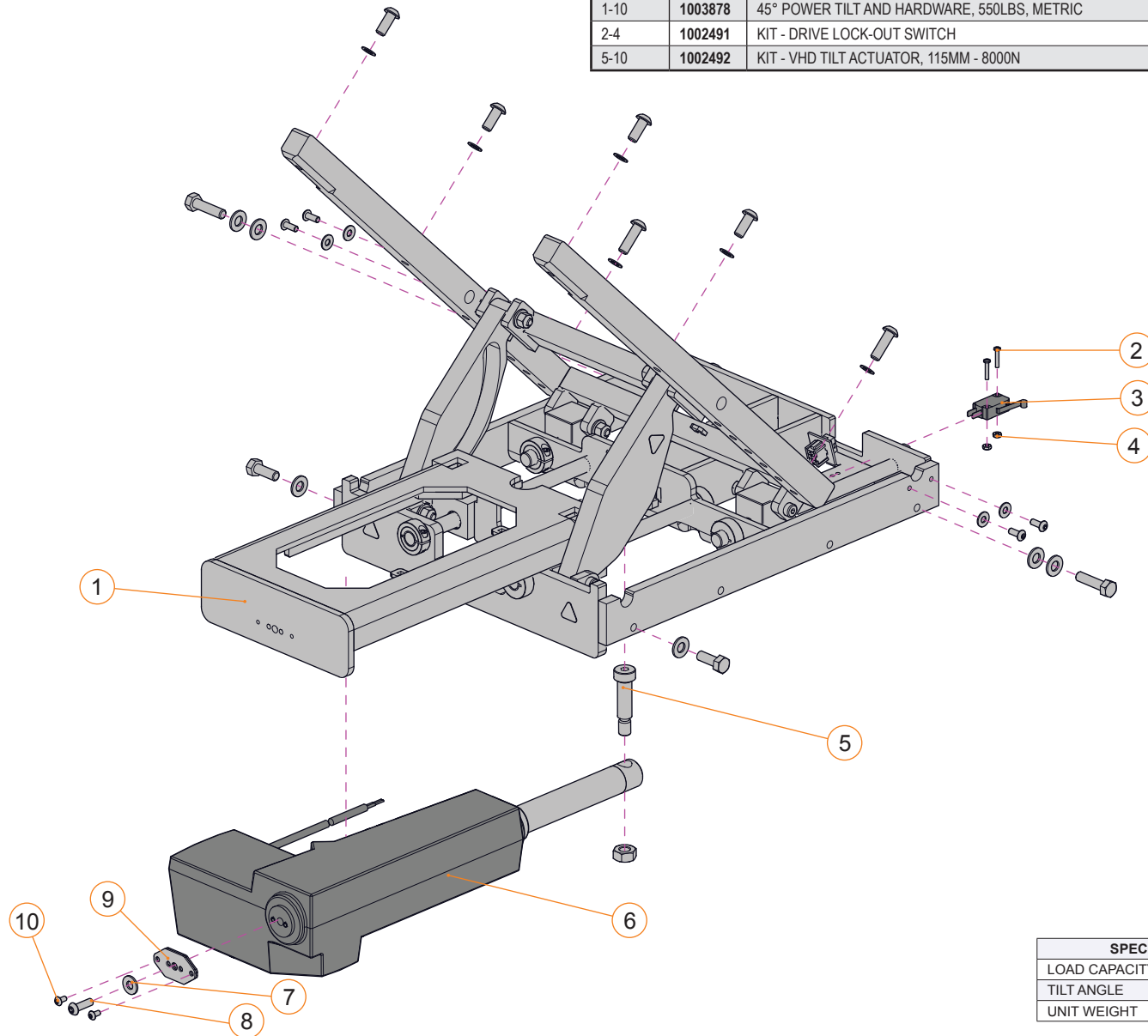

SPECIFICATIONS	
LOAD CAPACITY	550 LB USER
TILT ANGLE	0°-45°
UNIT WEIGHT	45 LB

POWER SEAT ELEVATOR, 300 LB WEIGHT CAP			
ITEM #	PART #	DESCRIPTION	PRIOR TO
1-6	C-4260	POWER SEAT ELEVATOR, 300 LB WEIGHT CAP	2020-02-03
2	R00032	ACTUATOR, STROKE 127 MM 6000N	2020-02-03
3	E00187	HEX BOLT M12 X 35 MM	2020-02-03
4	E00175	CAP SCREW M6 X 15 MM	2020-02-03
5	E00079	4-40 X 5/8 SCREW	2020-02-03
6	B00007	MECHANICAL LIMIT SWITCH	2020-02-03

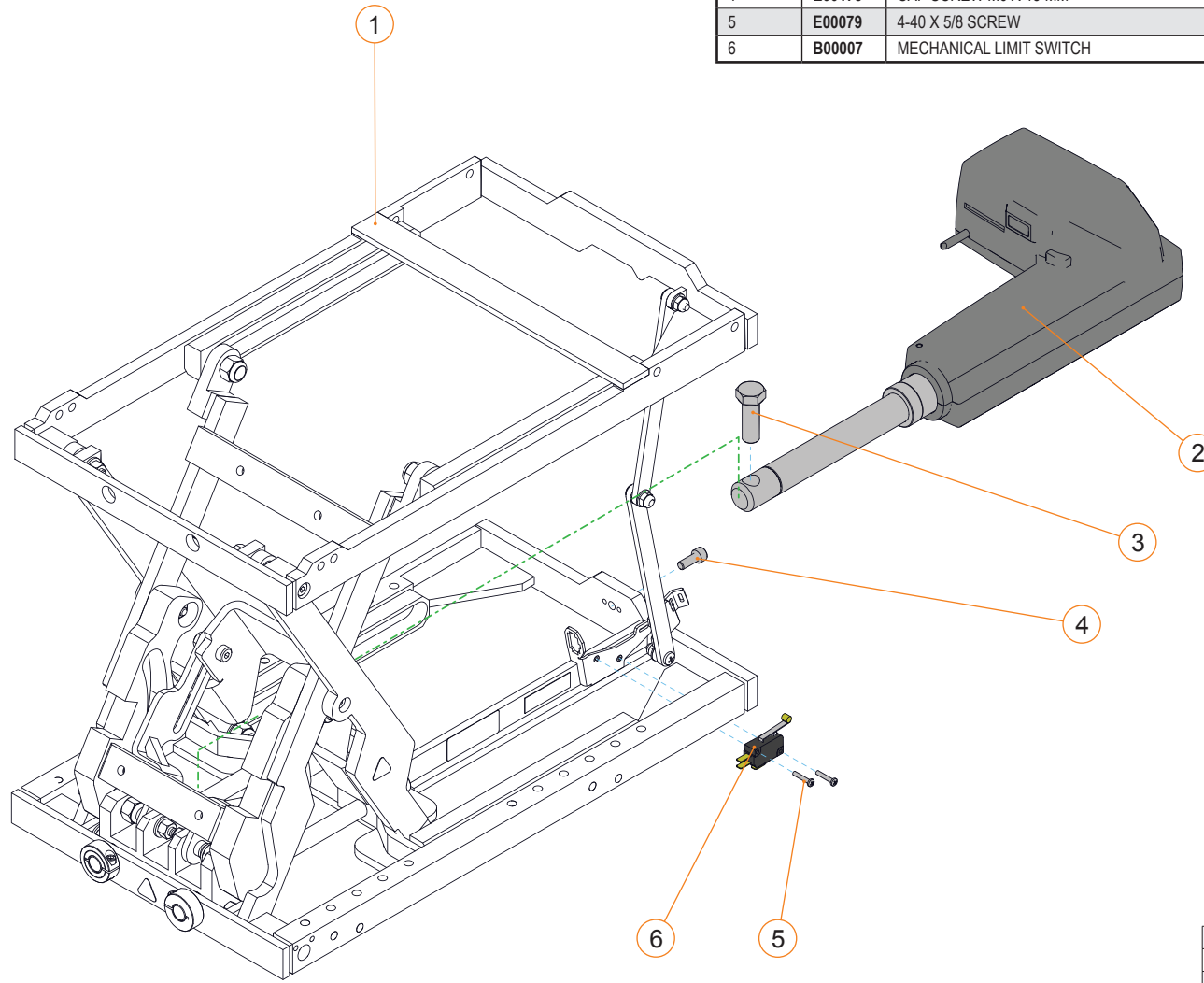

SPECIFICATIONS	
LOAD CAPACITY	300 LB USER
ELEVATION	0'-11"
UNIT WEIGHT	43 LB

POWER ELEVATE MODULE - SECTION 1.2

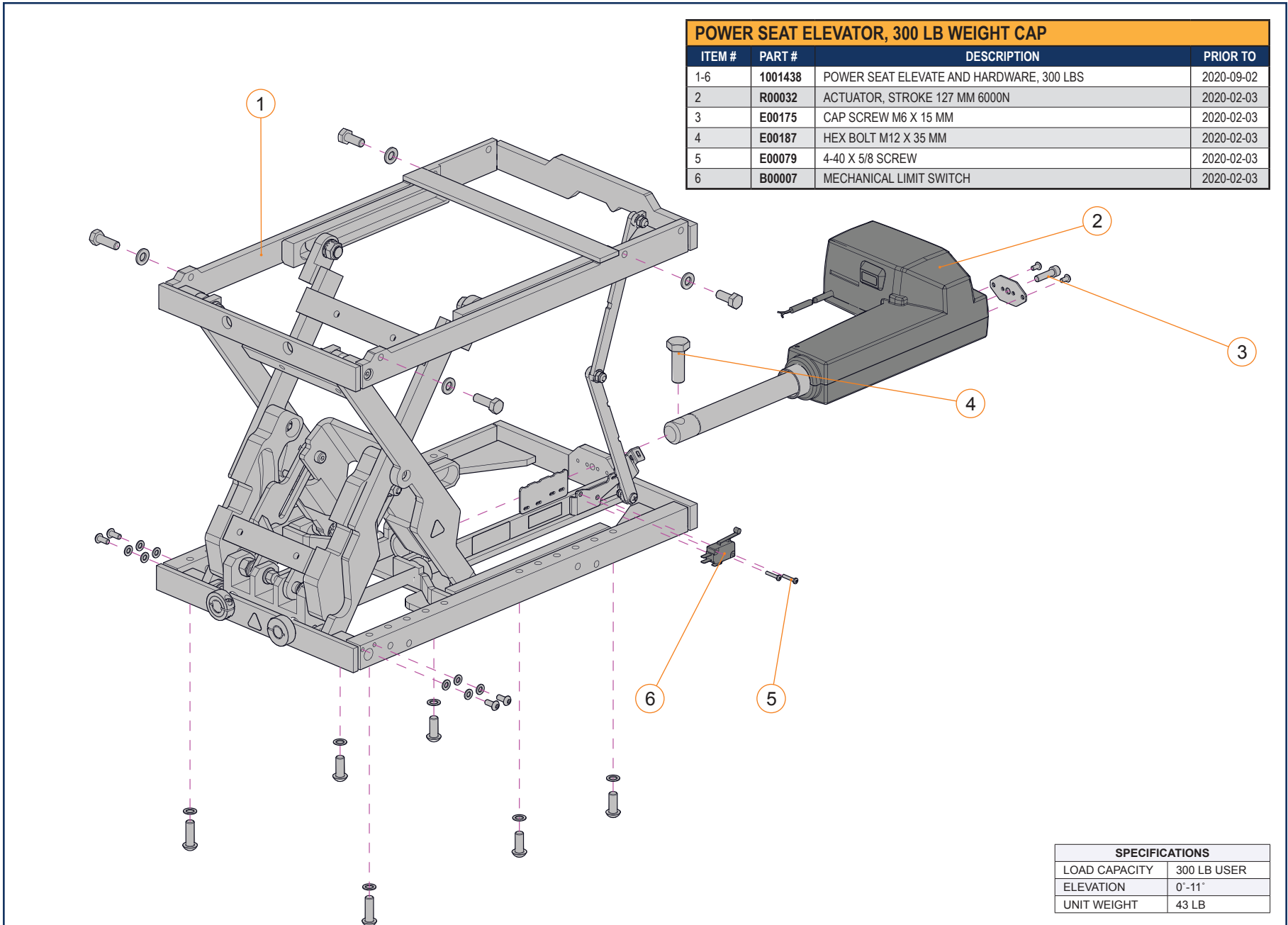

POWER SEAT ELEVATOR, 300 LB WEIGHT CAP			
ITEM #	PART #	DESCRIPTION	PRIOR TO
1-6	1001438	POWER SEAT ELEVATE AND HARDWARE, 300 LBS	2020-09-02
2	R00032	ACTUATOR, STROKE 127 MM 6000N	2020-02-03
3	E00175	CAP SCREW M6 X 15 MM	2020-02-03
4	E00187	HEX BOLT M12 X 35 MM	2020-02-03
5	E00079	4-40 X 5/8 SCREW	2020-02-03
6	B00007	MECHANICAL LIMIT SWITCH	2020-02-03

SPECIFICATIONS	
LOAD CAPACITY	300 LB USER
ELEVATION	0'-11"
UNIT WEIGHT	43 LB

POWER SEAT ELEVATOR, 300 LB WEIGHT CAP, CONNECTOR E-BX			
ITEM #	PART #	DESCRIPTION	EFFECTIVE
1-4	1001064	POWERED SEAT ELEVATOR E-BX, 300LBS WEIGHT CAP	2020-02-03
1-6	S-0185	POWERED SEAT ELEVATOR FOR SOLO/DUO/ISM 300LBS	2020-02-03
2-4	S-0186	IQ ACTUATOR ELEVATE, STROKE 127MM 6000N	2020-02-03
5-6	S-0203	DRIVE LOCK-OUT SWITCH FOR ELEVATE	2020-02-03

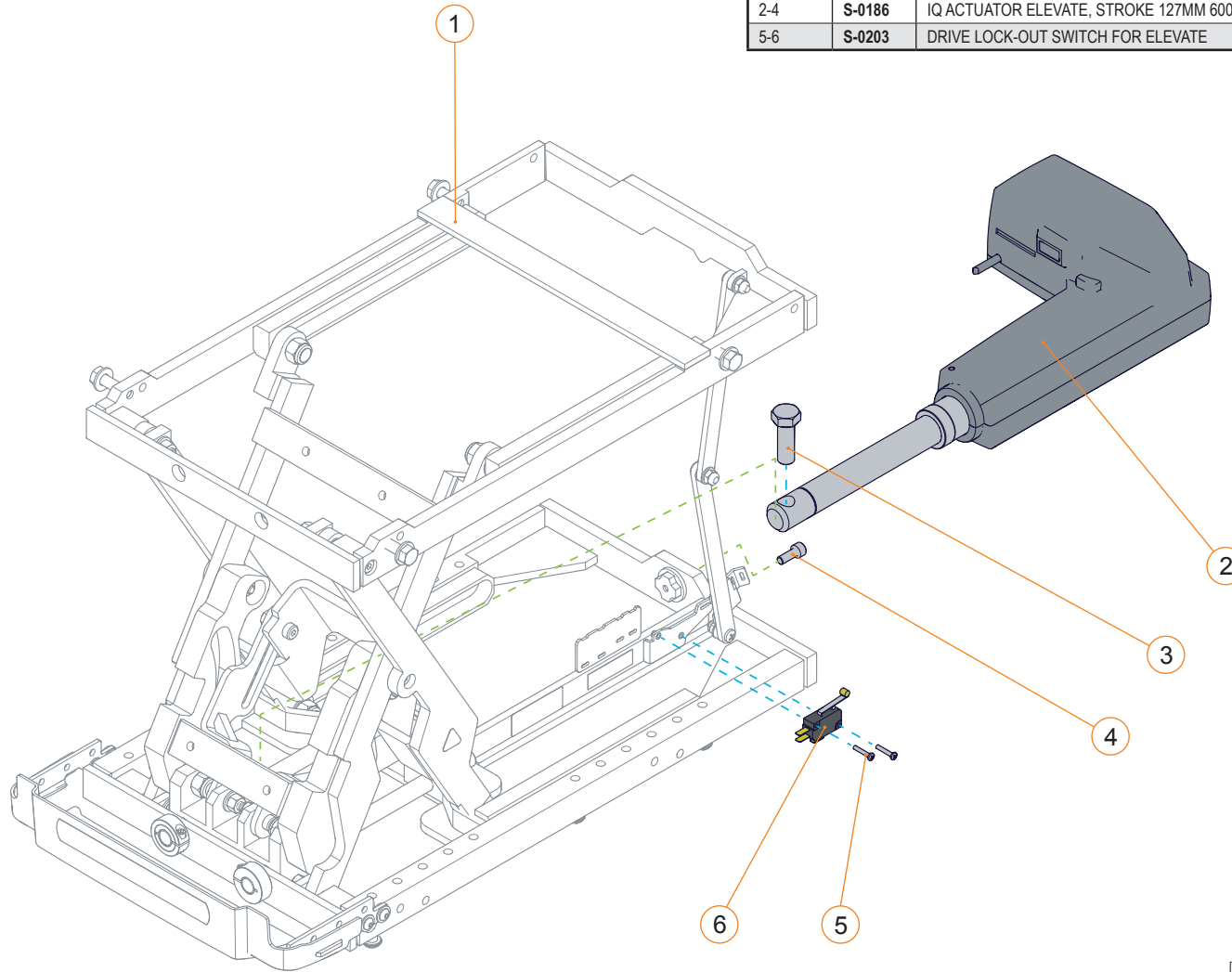

SPECIFICATIONS	
LOAD CAPACITY	300 LB USER
ELEVATION	0"-11"
UNIT WEIGHT	46 LB

POWER ELEVATE MODULE - SECTION 1.2

POWER SEAT ELEVATOR, 300 LB WEIGHT CAP, CONNECTOR E-BX

ITEM #	PART #	DESCRIPTION	EFFECTIVE
1-6	1001497	POWERED SEAT ELEVATOR EBX & HARDWARE, 300 LBS	2020-09-02
1-8	1001445	POWERSEAT ELEV FOR SOLO/DUO/ISM, 300LB	2020-09-02
2-6	S-0186	IQ ACTUATOR ELEVATE, STROKE 127MM 6000N	2021-05-03
7, 8	S-0203	DRIVE LOCK-OUT SWITCH FOR ELEVATE	2020-02-03

SPECIFICATIONS	
LOAD CAPACITY	300 LB USER
ELEVATION	0"-11"
UNIT WEIGHT	46 LB

POWER SEAT ELEVATOR, 400 LB WEIGHT CAP			
ITEM #	PART #	DESCRIPTION	PRIOR TO
1-6	C-4300	POWER SEAT ELEVATOR, 400 LB WEIGHT CAP	2017-01-23
2	R00034	ACTUATOR, STROKE 127 MM 8000N	2012-12-19
3	E00187	HEX BOLT M12 X 35 MM	2011-08-02
4	E00175	CAP SCREW M6 X 15 MM	2011-08-02
5	E00079	4-40 X 5/8 SCREW	2011-05-06
6	B00007	MECHANICAL LIMIT SWITCH	2008-04-30

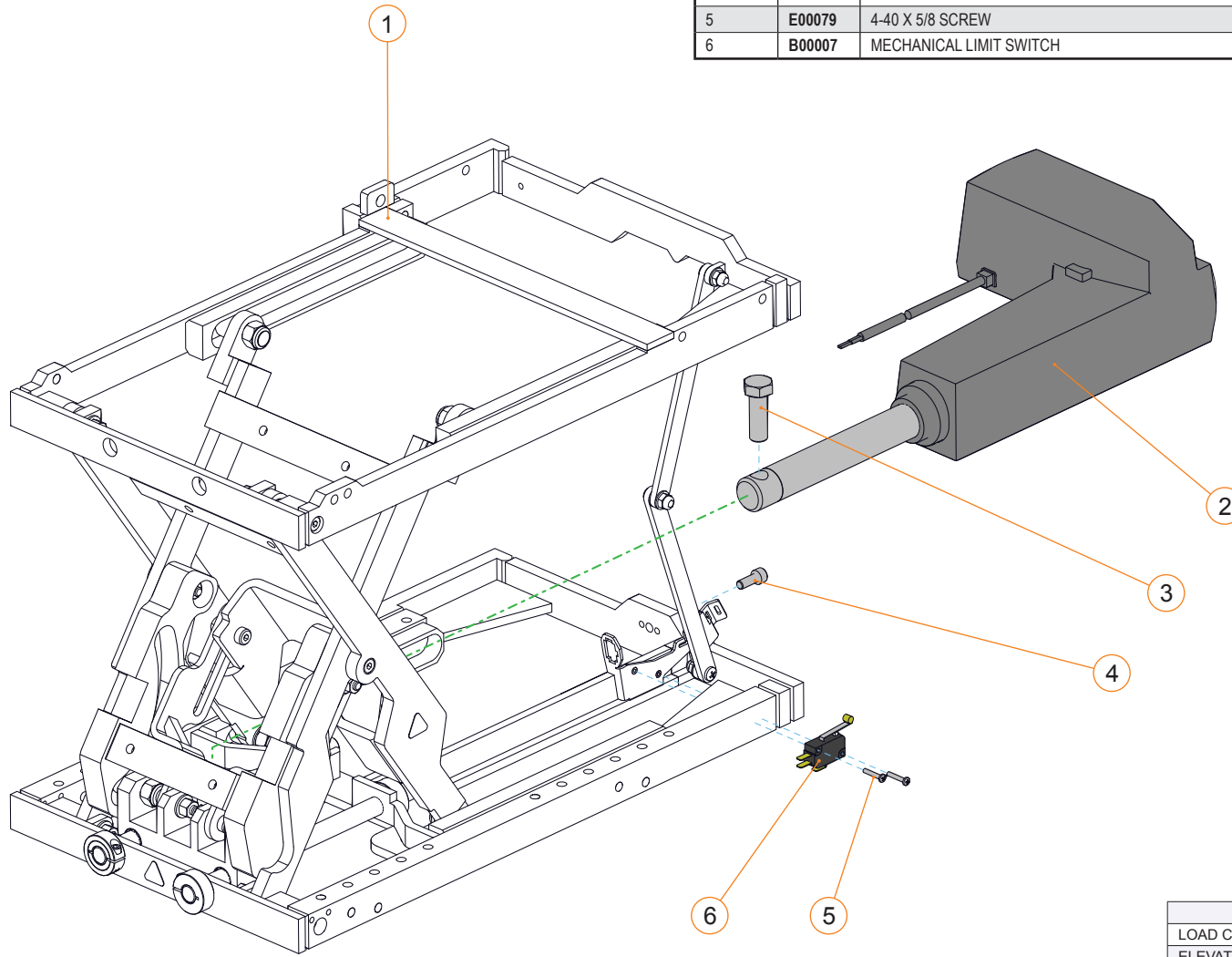

SPECIFICATIONS	
LOAD CAPACITY	400 LB USER
ELEVATION	0'-11"
UNIT WEIGHT	46 LB

POWER SEAT ELEVATOR, 400 LB WEIGHT CAP			
ITEM #	PART #	DESCRIPTION	EFFECTIVE
1-8	1001452	POWERED SEAT ELEVATOR AND HARDWARE, 400 LBS	2020-09-02
2-6	1002494	KIT - ACTUATOR HD ELEVATE, 127MM - 8000N	2021-05-03
7, 8	1002493	KIT - DRIVE LOCK-OUT SWITCH FOR ELEVATE	2021-02-12

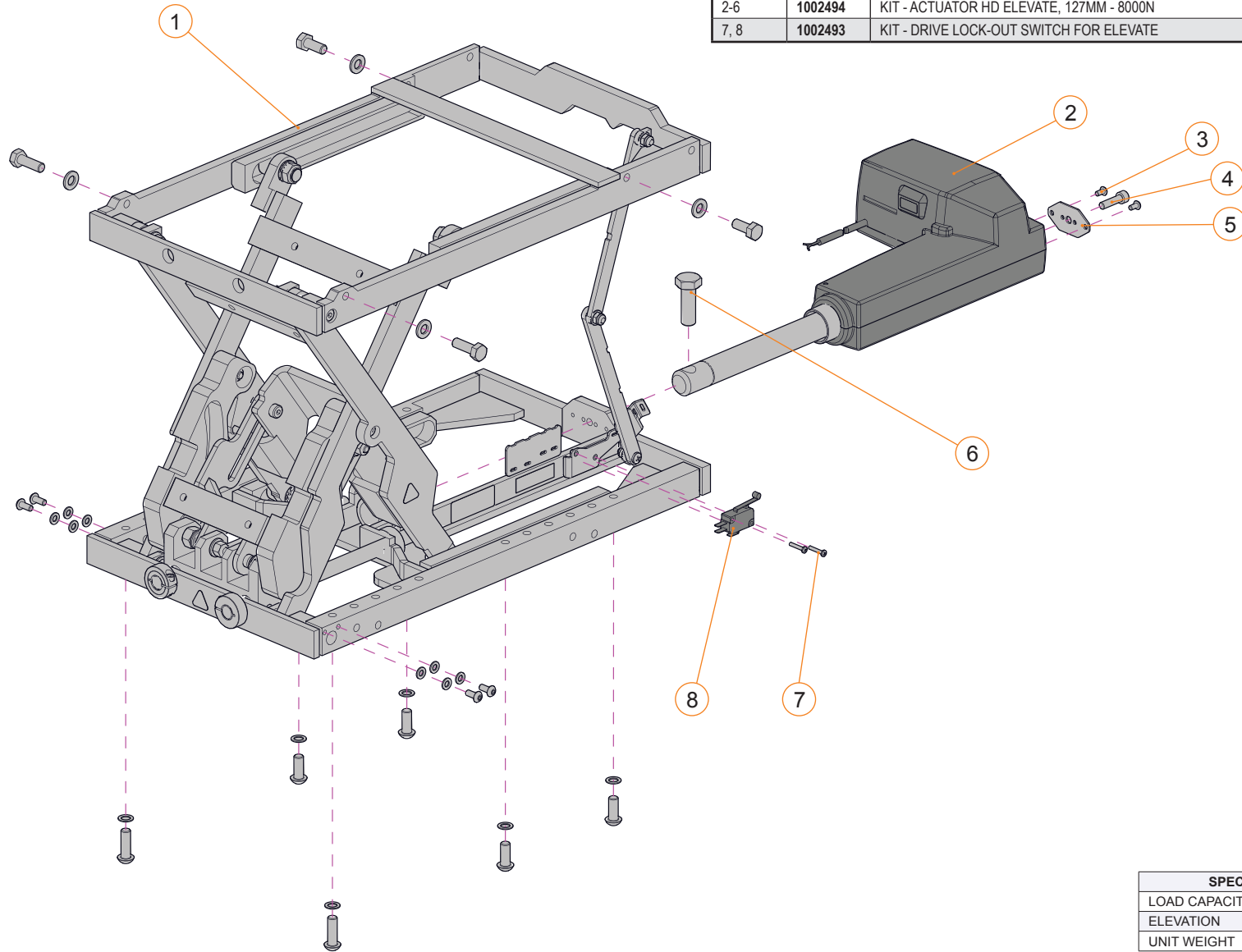

SPECIFICATIONS	
LOAD CAPACITY	400 LB USER
ELEVATION	0'-11"
UNIT WEIGHT	46 LB

THIS SECTION HAS BEEN INTENTIONALLY LEFT BLANK

ASCENT POWER STANDING MODULE			
ITEM #	PART #	DESCRIPTION	EFFECTIVE
1-11	S-0157	POWER STANDING MODULE	2019-09-03
2	S-0159	ACTUATOR 24 V STANDER EBX 155 MM, 2500N - RH	2019-09-03
3	S-0160	KIT, SHROUD FOR STANDING MODULE	2019-09-03
4-11	S-0158	ACTUATOR 24 V STANDER EBX 155 MM, 2500N - LH	2019-09-03

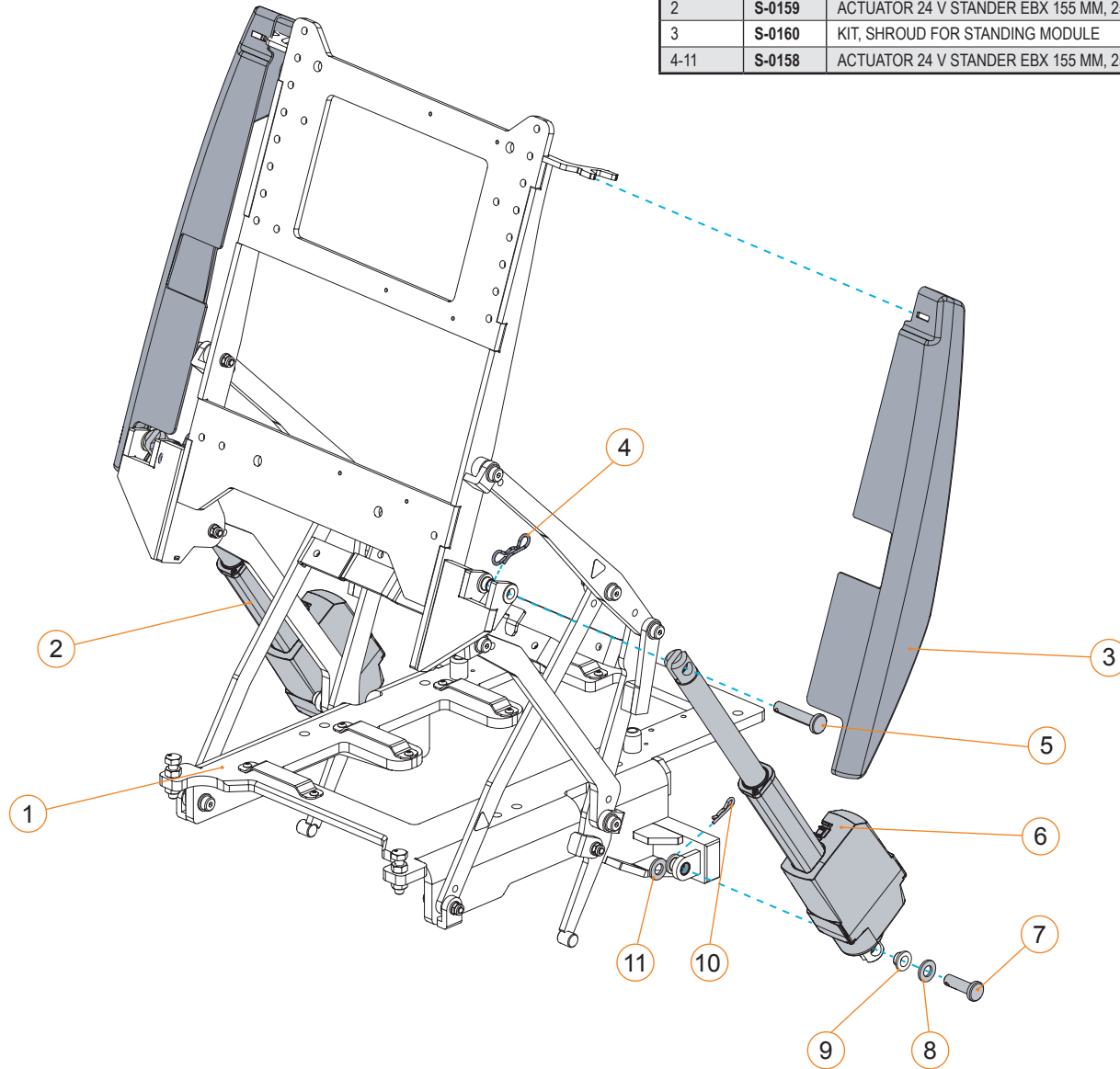

SPECIFICATIONS	
LOAD CAPACITY	250 LB USER
TILT ANGLE	0°-70°
UNIT WEIGHT	42 LB

ANTI-TIP ASSEMBLY FOR ASCENT STANDING MODULE			
ITEM #	PART #	DESCRIPTION	EFFECTIVE
1	S-0161	NYLON WEAR SHIM FOR ANTI-TIP BLOCK	2019-09-03
1,2A,3	S-0162	ANTI-TIP ASSEMBLY, LH	2019-09-03
1,2B,3	S-0163	ANTI-TIP ASSEMBLY, RH	2019-09-03
3	S-0237	SPRING KIT, ANTI-TIP	2019-09-03

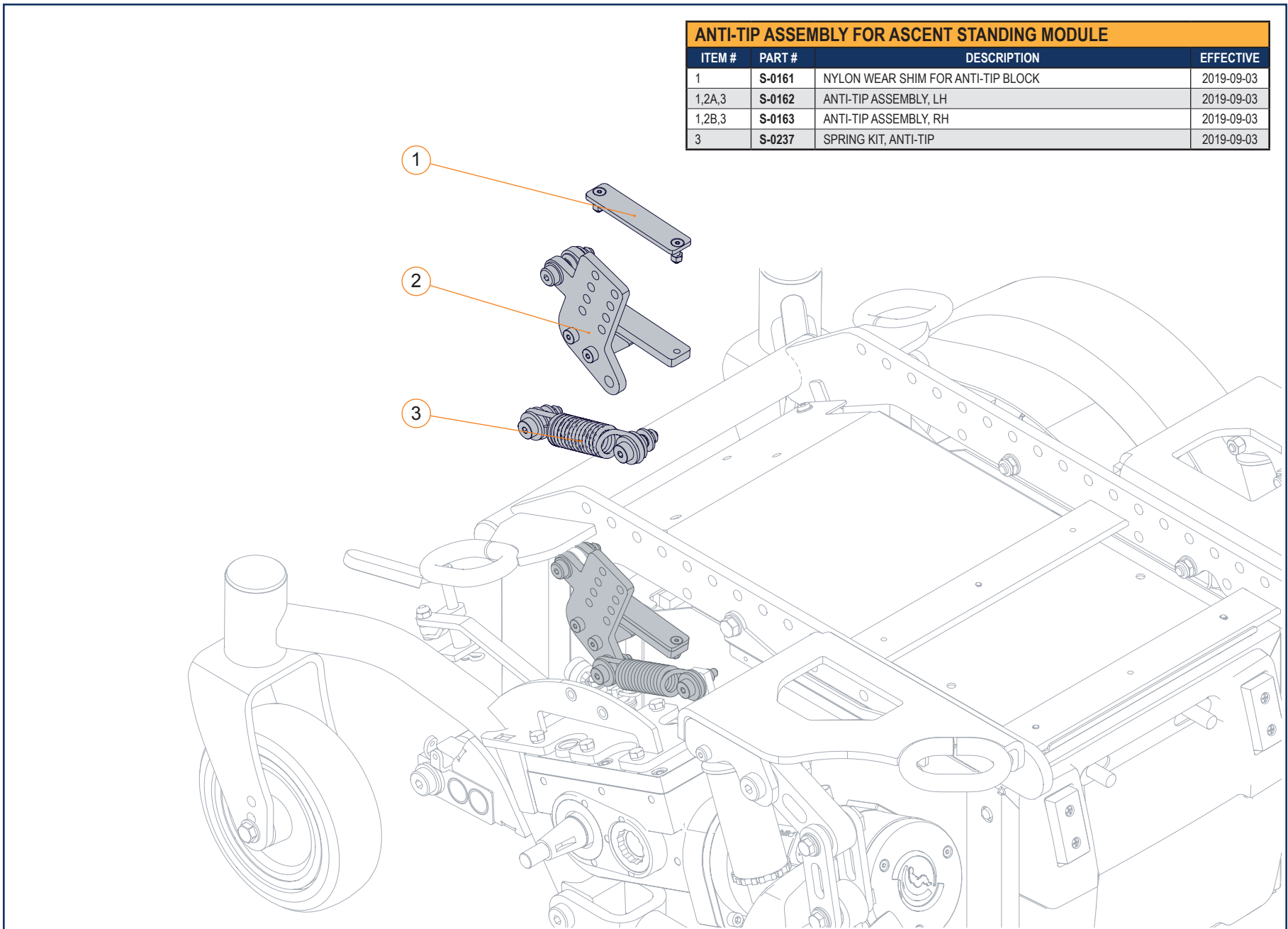

NO MODULE INSTALLATION			
ITEM #	PART #	DESCRIPTION	EFFECTIVE
1,2A	1001676	STANDARD SHROUD, WITH REFLECTOR	2020-11-02
1,2B	1001678	VHD SHROUD, WITH REFLECTOR	2020-11-02
1,2A-5,6A,7-9	C-64135	REAR STANDARD SEATING SHROUD INSTALLATION KIT	2015-08-01
1,2B-5,6B,7-9	C-64139	REAR VHD SEATING SHROUD INSTALLATION KIT	2015-08-01

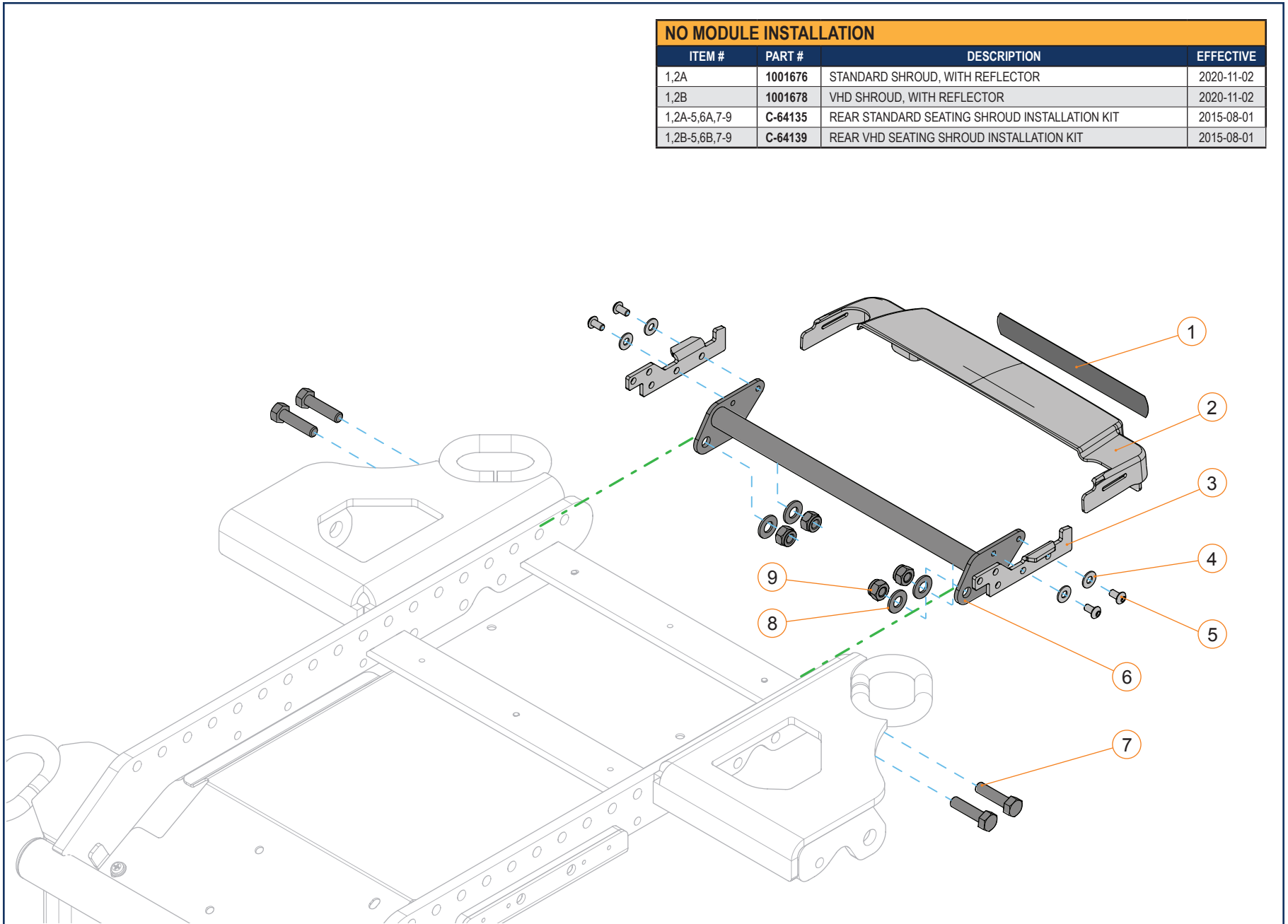

SHROUDS - SECTION 1.5

TILT			
ITEM #	PART #	DESCRIPTION	EFFECTIVE
1,2A	1001676	STANDARD SHROUD, WITH REFLECTOR	2020-11-02
1,2B	1001678	VHD SHROUD, WITH REFLECTOR	2020-11-02
1, 2A, 3-8	C-64136	TILT AND REAR SHROUD INSTALLATION KIT	2015-05-14
1, 2B, 3-8	C-64140	VHD TILT AND REAR SHROUD INSTALLATION KIT	2015-08-01

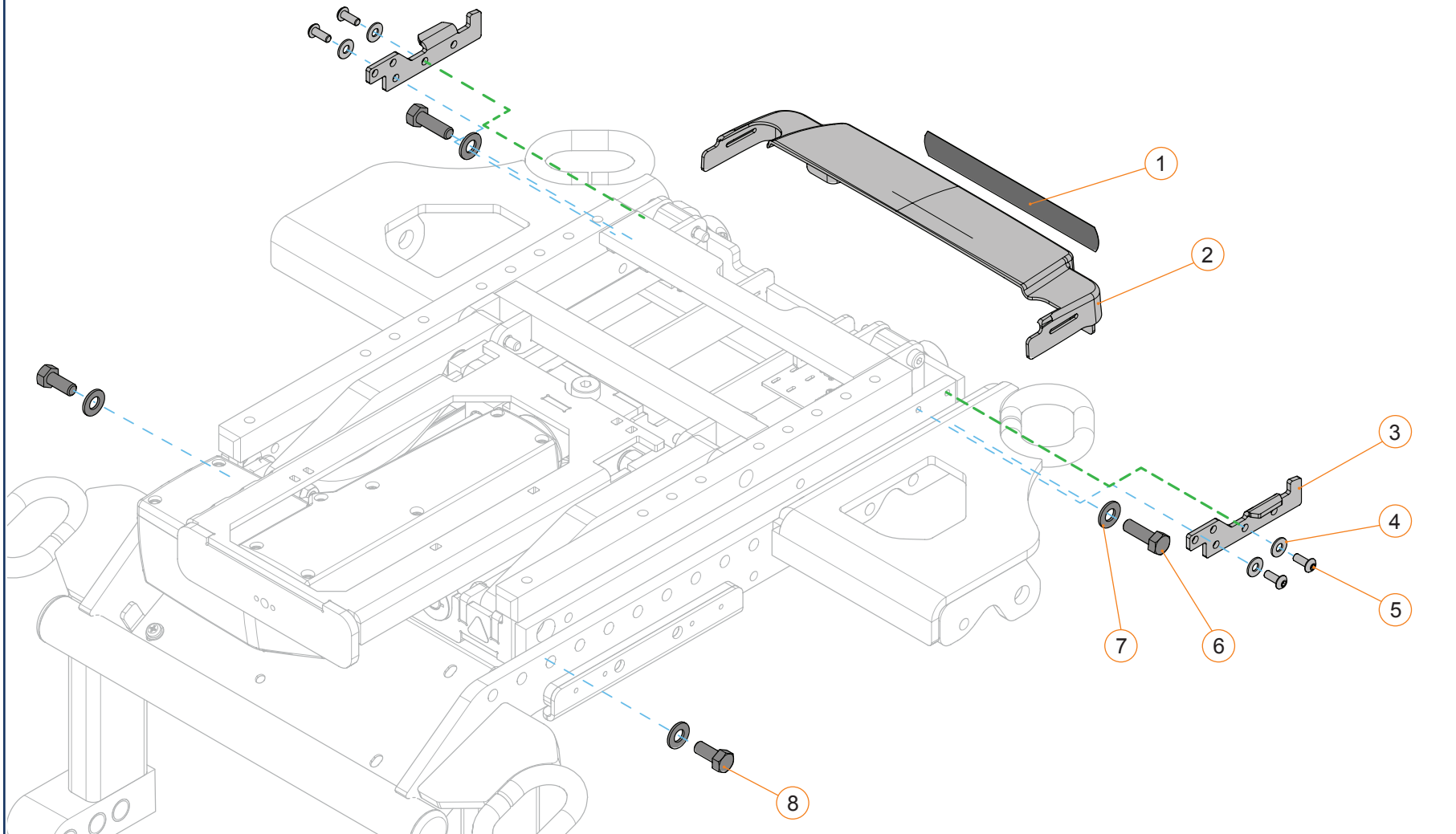

SHROUDS - SECTION 1.5

TILT			
ITEM #	PART #	DESCRIPTION	EFFECTIVE
1,2A	1001676	STANDARD SHROUD, WITH REFLECTOR	2020-11-02
1,2B	1001678	VHD SHROUD, WITH REFLECTOR	2020-11-02
1, 2A, 3-8	1001417	TILT AND REAR SHROUD INSTALLATION KIT	2020-11-16
1, 2B, 3-8	1003721	VHD TILT AND REAR SHROUD INSTALLATION KIT, METRIC	2022-04-01

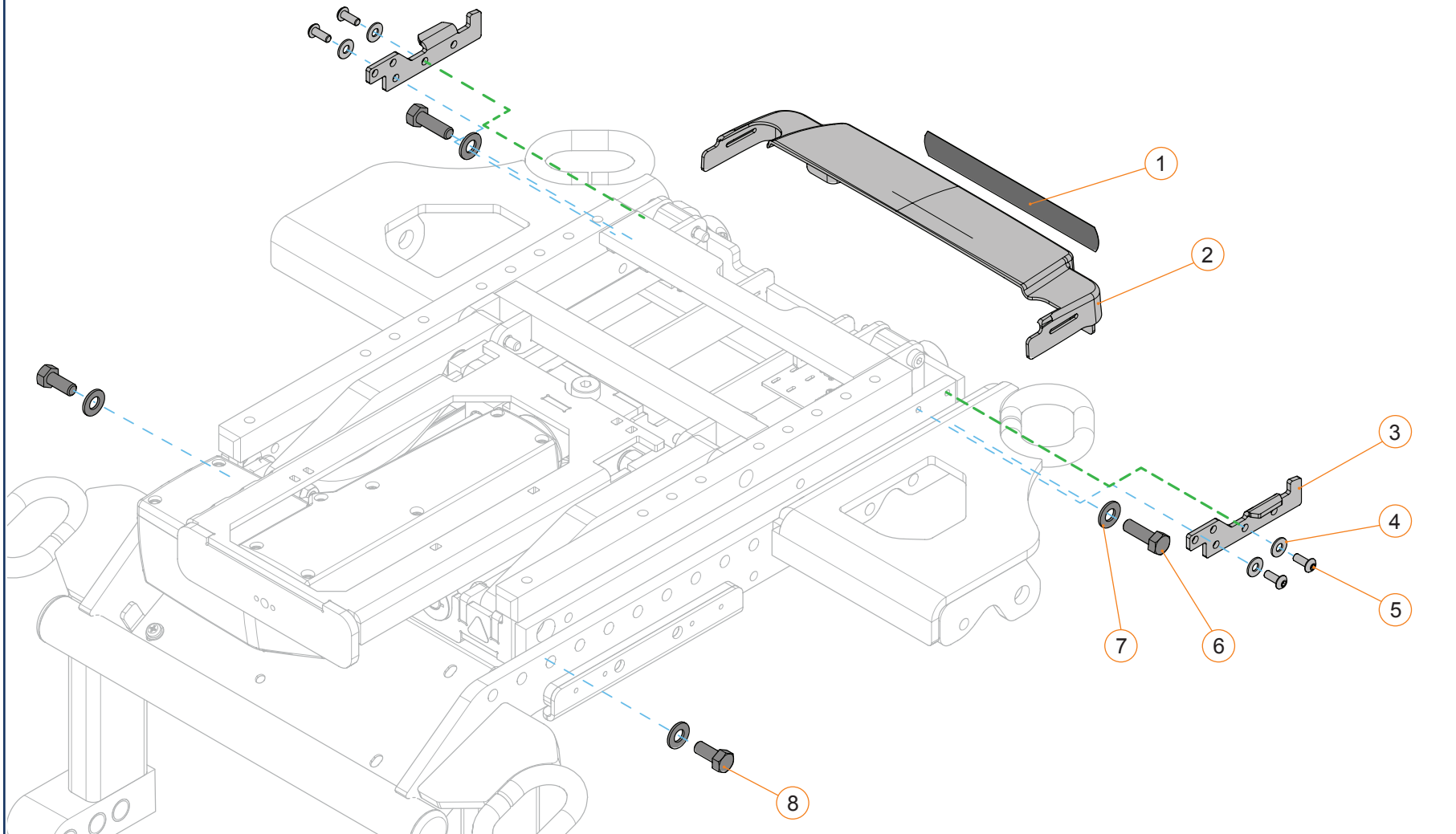

SHROUDS - SECTION 1.5

ELEVATE			
ITEM #	PART #	DESCRIPTION	EFFECTIVE
1-2	1001676	STANDARD SHROUD, WITH REFLECTOR	2020-11-02
1-8	1001416	SEAT ELEVATOR AND REAR SHROUD INSTALLATION KIT	2020-11-16

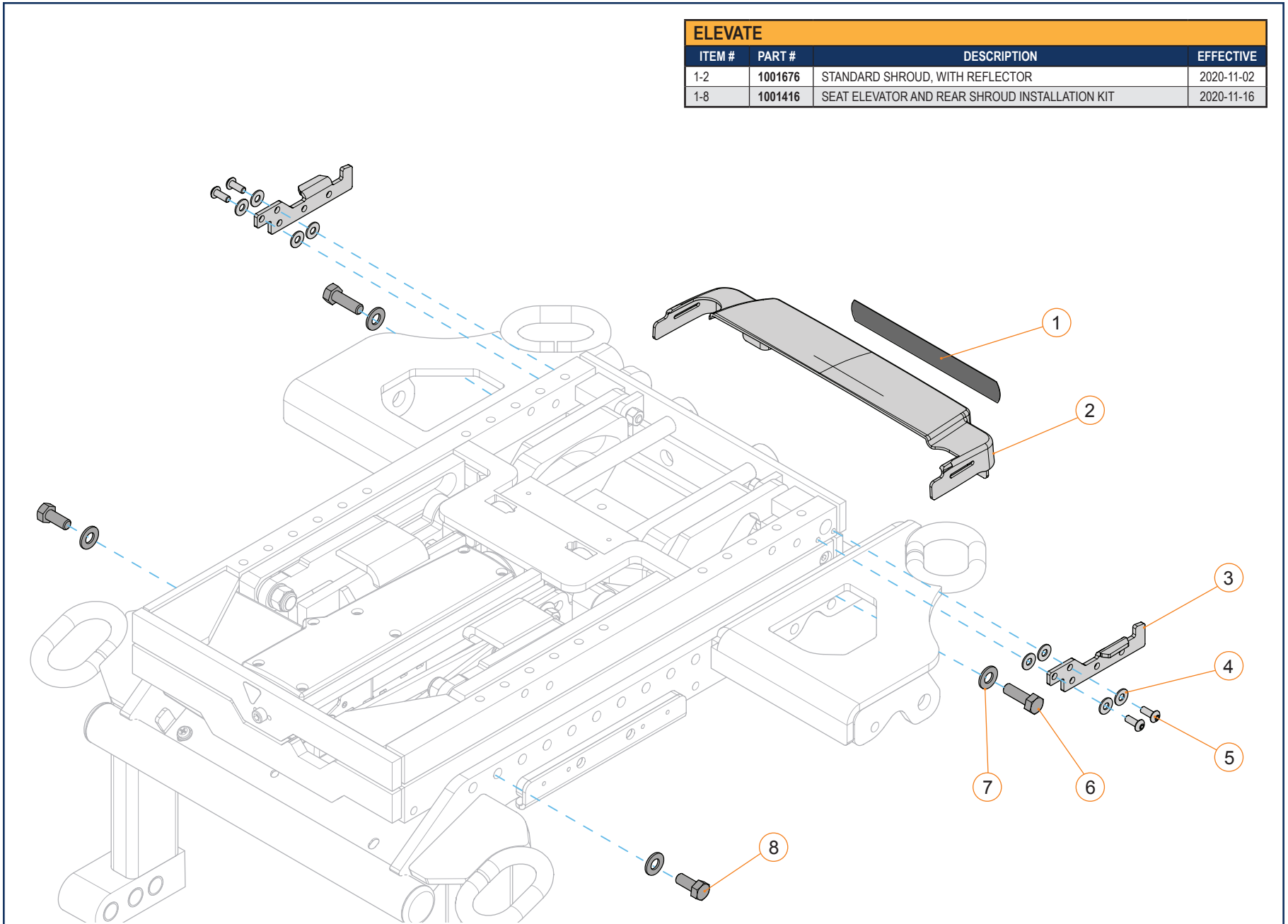

SHROUDS - SECTION 1.5

COMBO			
ITEM #	PART #	DESCRIPTION	EFFECTIVE
1-2	1001677	STANDARD COMBO SHROUD, WITH REFLECTOR	2020-11-02
1-8	1001418	COMBO AND REAR SHROUD INSTALLATION KIT	2020-11-16

