

# INSTRUCTION GUIDE

## *ADJUSTING THE NEW “SIGNATURE” FRONT RIGGING AND RELATED COMPONENTS*



*Adjusting the new SIGNATURE front rigging (cont'd)*

Contents

INTRODUCTION .....3

ADJUSTEMENTS .....3

1. Adjusting Leg Length ..... **3**

    1.1 For Standard (STD), Heavy-Duty (HD) Footrests, Manual & Powered Elevating/Articulating Legrests .....3

    1.2. For Pediatric models .....4

2. Adjusting Footplate Angle..... **5**

    2.1 For Standard (STD), Heavy-Duty (HD) Footrests, Manual & Powered Elevating/Articulating Legrests .....5

    2.2. For Pediatric models .....6

3. Adjusting Footplate Depth ..... **7**

    3.1 For angle-adjustable footplate adapters .....8

    3.2. For fixed footplate adapters .....9

4. Adjusting Calf Pads ..... **9**

    4.1 Height adjustment.....10

    4.2. Installing a new pair of calf pads.....11

    4.3. Depth adjustment.....14

5. Adjusting Knee Angle ..... **13**

    5.1 For Standard (STD) or Pediatric Legrests.....15

    5.2. For Heavy-Duty (HD) Footrests, Manual & Powered Elevating/Articulating Legrests .....17

## Adjusting the new SIGNATURE front rigging (cont'd)

### INTRODUCTION

The following instructions specify how to perform all adjustments related to the new Signature front rigging, including standard (STD) and heavy-duty (HD) swing-away footrests, pediatric footrests and elevating & articulating legrests (ALR) both manual and power. Please note, the manual and power elevating legrests are comprised of the same hanger used with our HD footrests. This provides parts continuity and allows for harmonized adjustments across the line. If any steps are unclear, please contact Amylior Technical Support.

### ADJUSTMENTS

#### 1. Adjusting Leg Length

##### 1.1. For Standard (STD), Heavy-Duty (HD) Footrests, Manual & Power Elevating/Articulating Legrests

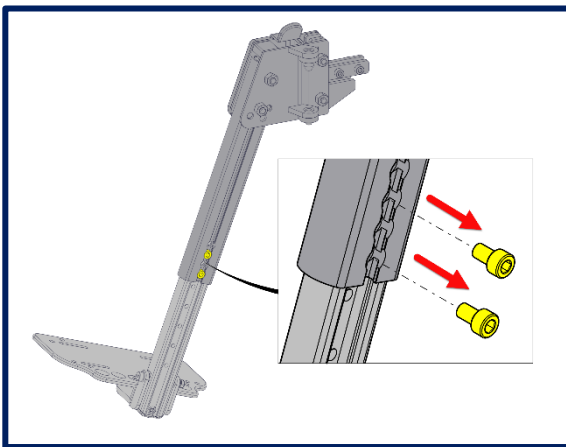

- a) Using a 5 mm Allen key, unscrew the two screws shown to separate the bottom extrusion from the top one.

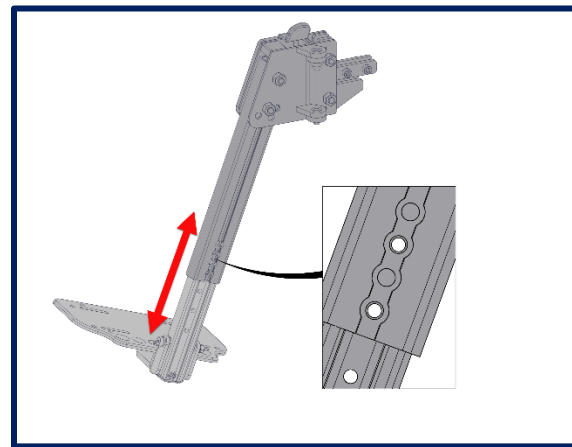

- b) Slide the lower part of the legrest to the desired height making sure to align the extrusion holes. Adjustment is made in  $\frac{1}{2}$ " (12.5 mm) increments according to the following ranges:  
 SOFLA12: 12 $\frac{1}{2}$ " - 17 $\frac{1}{2}$ " (320-445 mm)  
 SOFLA14: 14 $\frac{1}{2}$ " - 19 $\frac{1}{2}$ " (370-495 mm)

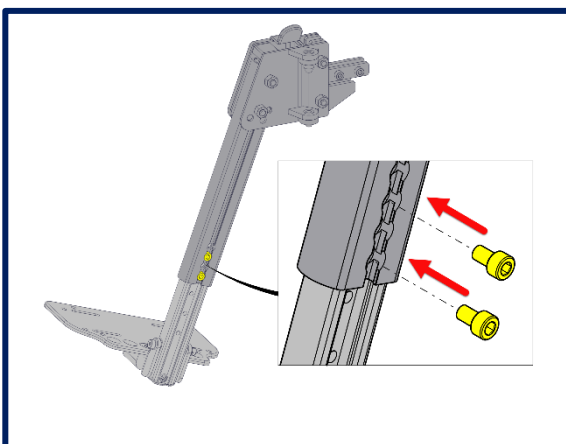

- c) Re-insert and screw both bolts to secure the bottom part to the top part.

## Adjusting the new SIGNATURE front rigging (cont'd)

### 1.2. For Pediatric models

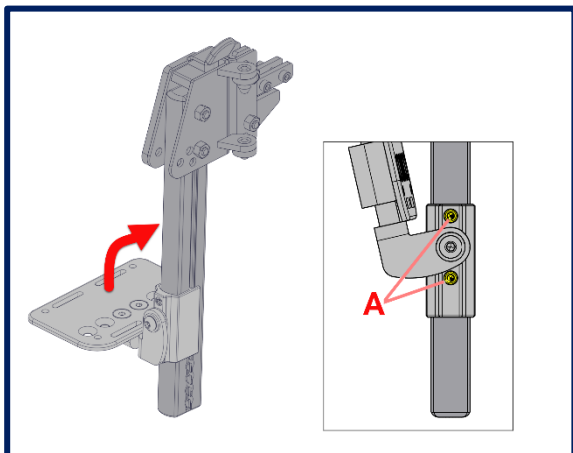

- a) Flip the footplate up to access the height adjustment bolts (A).

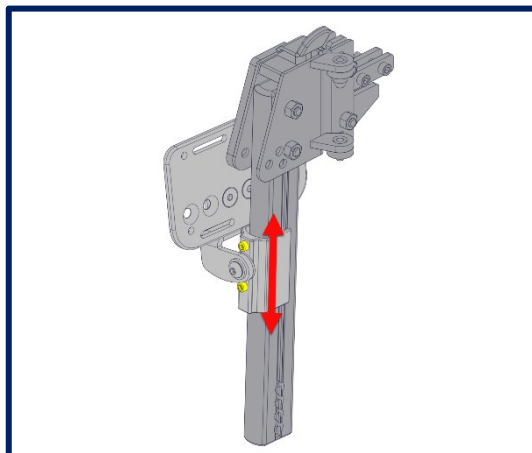

- b) To adjust the height, using a 5 mm Allen key, slightly loosen (**but do not remove**) both (B) bolts to allow the U extrusion to slide up or down.

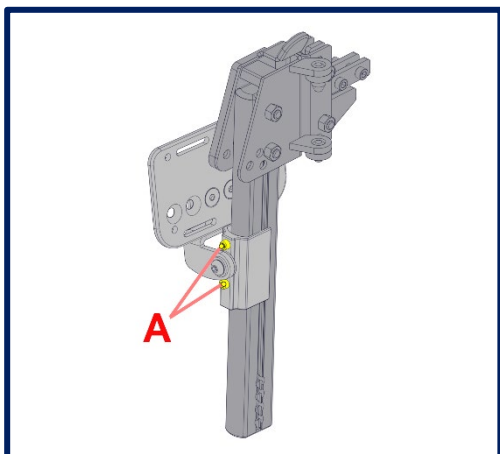

- c) Slide the extrusion to the desired height. Be careful not to remove the plastic end cap at the bottom during adjustment. Adjustment is infinite within the following ranges:  
 SOFLP5: 5" – 10" (125-255 mm)  
 SOFLP5L: 5" – 12" (125-305 mm)

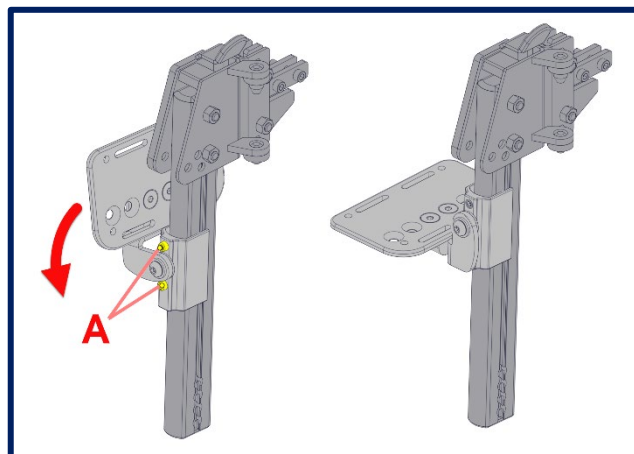

- d) Tighten bolts (A) securely and flip the footplate back down.

**NOTE:** If the footplate is difficult to flip up or down, see NOTE in section 2.2 for tension adjustment.

## Adjusting the new SIGNATURE front rigging (cont'd)

### 2. Adjusting Footplate Angle

#### Front View (of wheelchair).

##### 2.1. For Standard (STD), Heavy-Duty (HD) Footrests, Manual & Power Elevating/Articulating Legrests

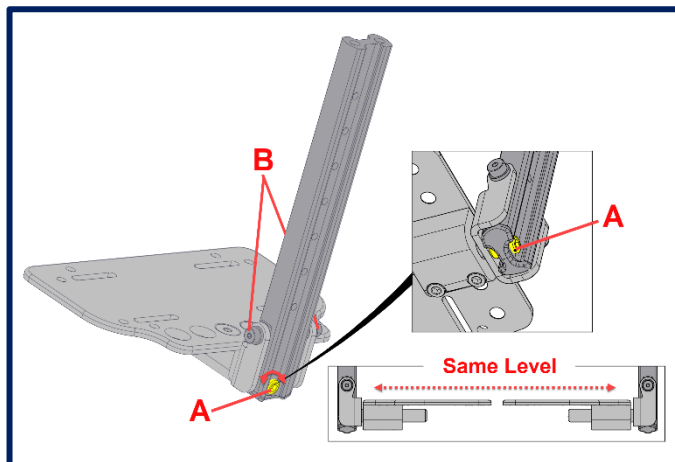

Using a 5 mm Allen key, tighten or loosen bolt (A) to adjust footplate angle. Normally, left, and right footrests should be at the same level.

**NOTE:** If the footplate is difficult to flip up or down, use a 3 mm Allen key and an 8 mm wrench to tighten/loosen the bolt/nut (B) to adjust the tension. Ideally, the footplate should maintain its angle without dropping downwards, while remaining easy to handle.

##### 2.2. For Pediatric models

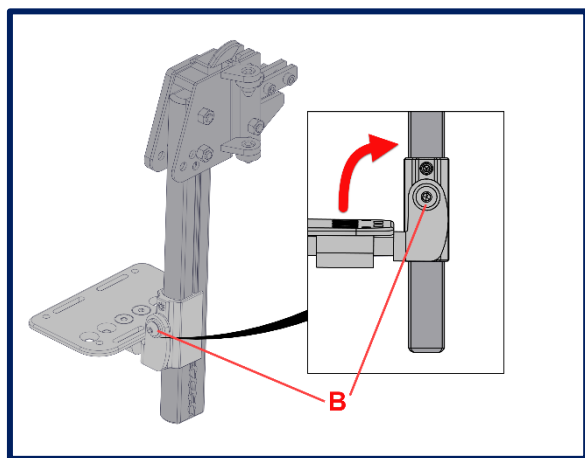

a) Flip footplate up to access adjustment bolt (B)

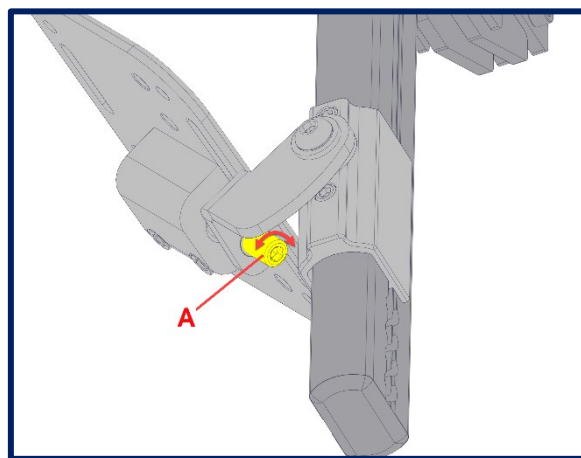

b) Tighten or loosen adjustment bolt (B) until desired angle is reached.

**NOTE:** If the footplate is difficult to flip up or down, use a 5 mm Allen key to tighten/loosen the bolt/nut (B) to adjust the tension. Ideally, the footplate should maintain its angle without dropping downwards, while remaining easy to handle.

## Adjusting the new SIGNATURE front rigging (cont'd)

### Side View

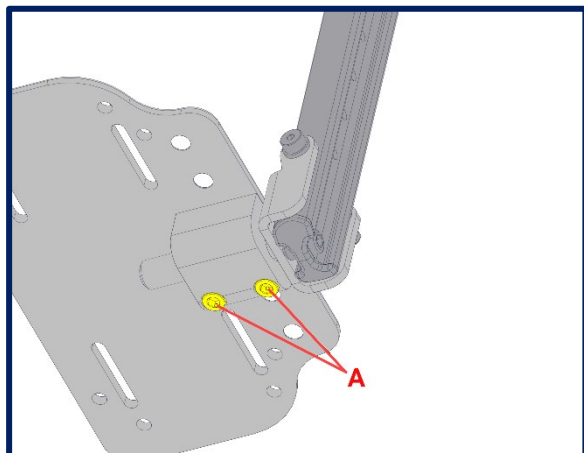

- a) Using a 5 mm Allen key, slightly loosen bolts (A) **without removing them completely**, to allow the footplate adapter to pivot on its axis.

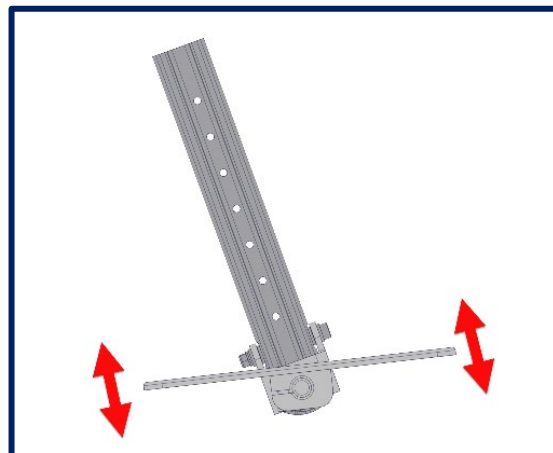

- b) Adjust the footrest to the desired angle. Make sure that the footplate adapter does not fall off the post, if it does, it is easily placed back on.

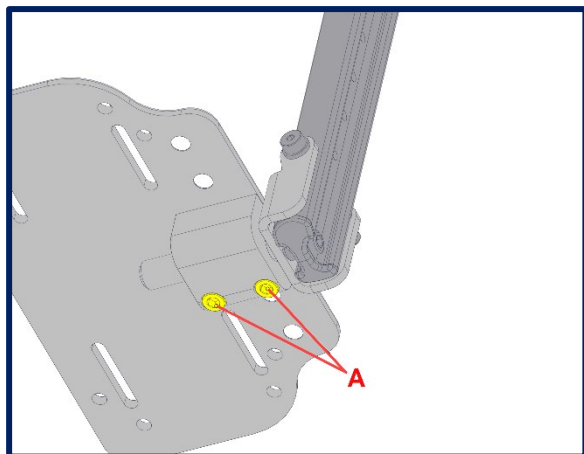

- c) Secure the footrest adapter on its axle, tightening both bolts (A) sufficiently to prevent the angle from changing during use.

## Adjusting the new SIGNATURE front rigging (cont'd)

### 3. Adjusting Footplate Depth

#### 3.1. For angle-adjustable footplate adapters

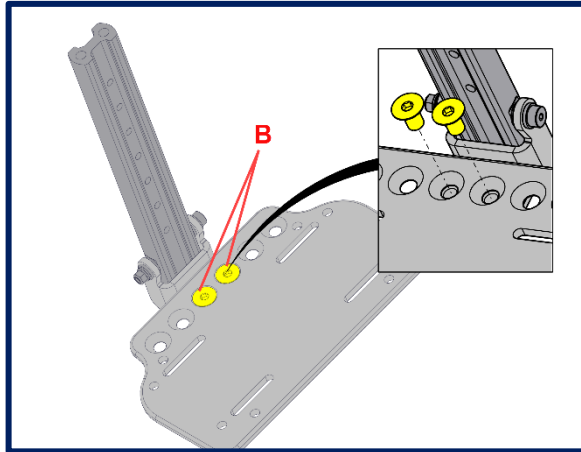

a) Using a 5 mm Allen key, unscrew both bolts (B) to detach the footplate from the adapter. Be careful not to drop the footplate or the bolts!

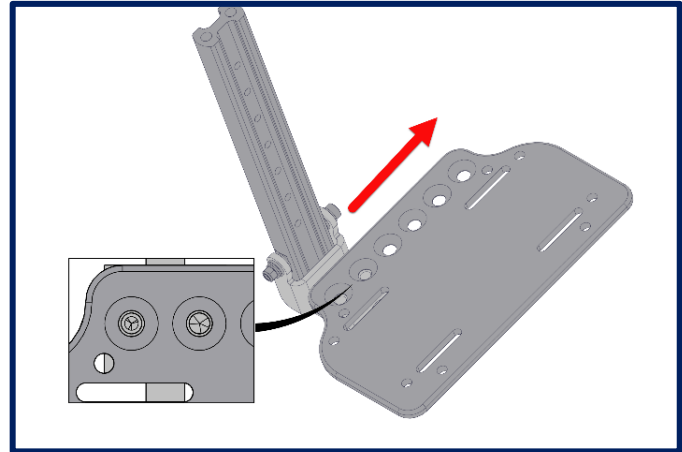

b) Adjust footplate to the desired depth by aligning the holes in the footplate with those on the adapter.

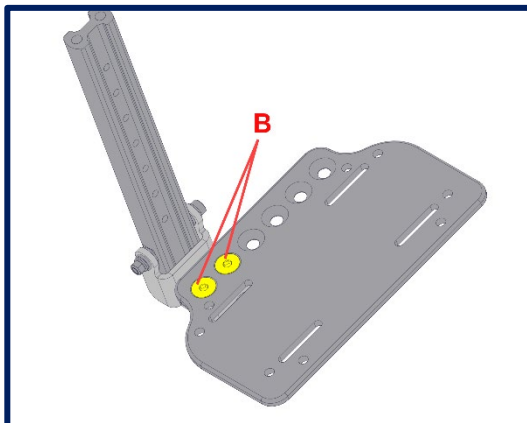

c) Retighten bolts (B) to secure the footplate to its adapter.

### Adjusting the new SIGNATURE front rigging (cont'd)

#### 3.2. For fixed footplate adapters

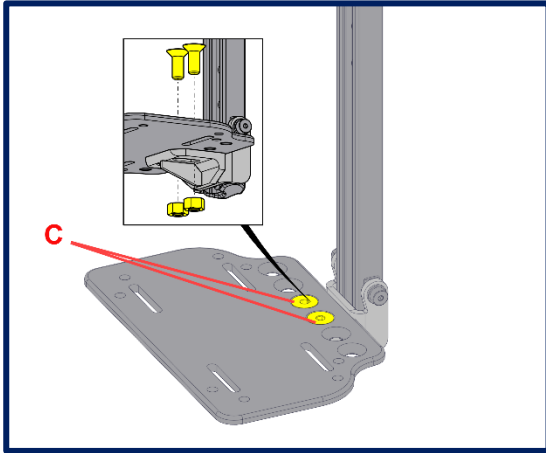

- a) Using a 5 mm Allen key and a 13 mm wrench, unscrew both bolts (C) from their nuts to release the footplate from its adapter. Be careful not to drop the footplate or the nuts & bolts!

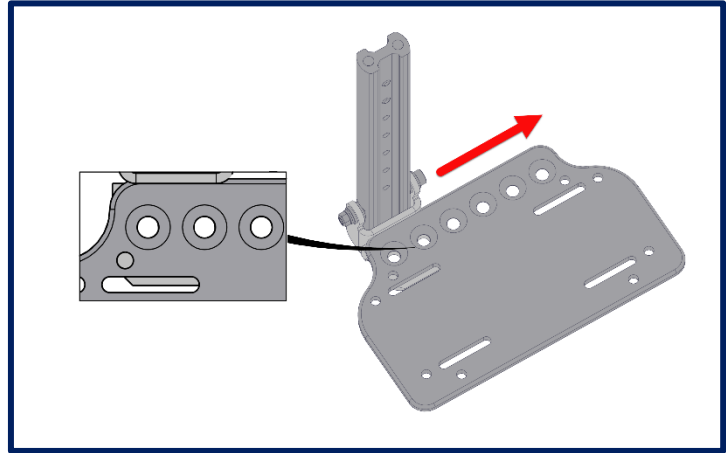

- b) Adjust footplate to the desired depth by aligning the holes in the footplate with those on the adapter.

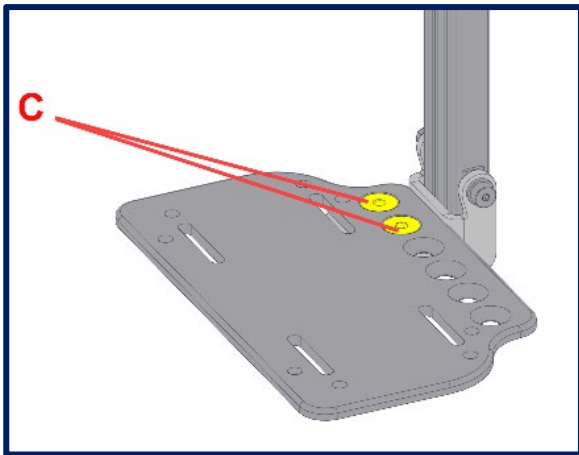

- c) Retighten bolts (C) to secure the footplate to its adapter.

## Adjusting the new SIGNATURE front rigging (cont'd)

### 4. Adjusting Calf Pads

#### 4.1. Height adjustment

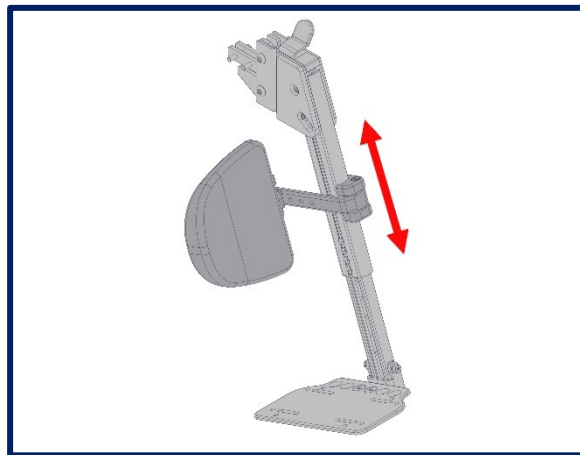
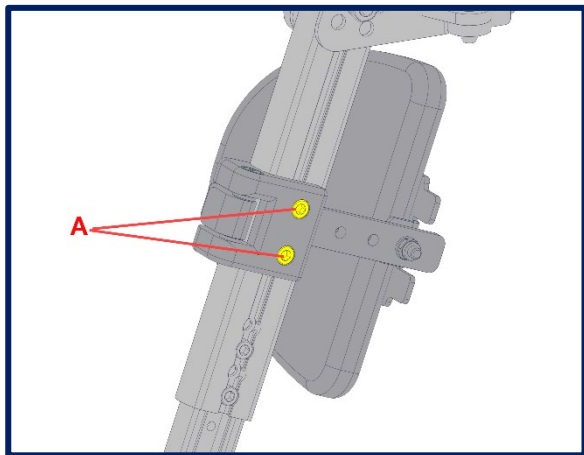

- a) Using a 5 mm Allen key, slightly loosen both bolts (A) to allow the calf pad to slide on the legrest extrusion. **Be careful not to unscrew the bolts too far**, to avoid separating the double T-nut from the mounting bracket.
- b) Adjust calf pad to the desired height. Adjustment is infinite within a range of 4¼" (110 mm).

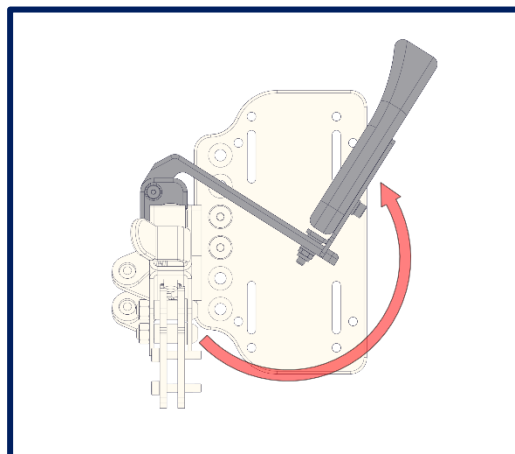
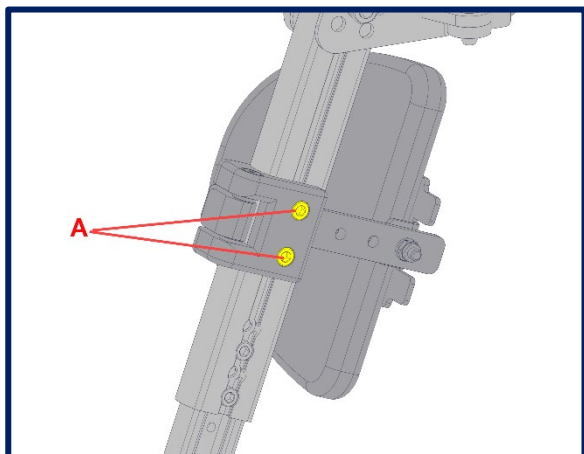

- c) Tighten bolts (A) to secure calf pad to legrest extrusion.

**NOTE:** The calf support is removable and can be rotated for better access some bolts. .

## Adjusting the new SIGNATURE front rigging (cont'd)

### 4.2. When inserting a new pair of calf pads

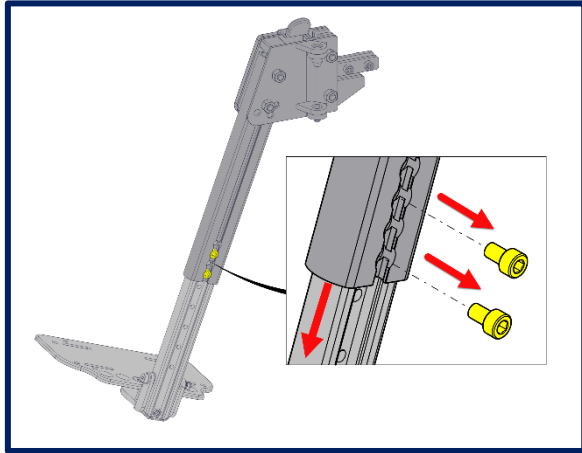

- a) Using a 5 mm Allen key, unscrew the two bolts to separate the bottom extrusion from the top.

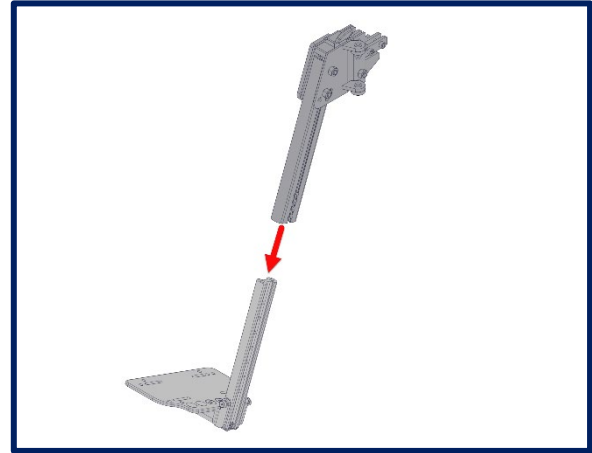

- b) Slide the bottom section off the top section of the legrest.

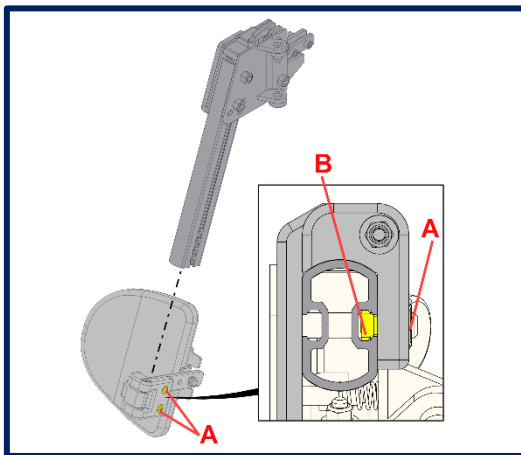

- c) Slightly loosen both bolts (A) (without removing them) to allow the calf pad support to slide up and down the extrusion. The T-nut (B) should be inserted into the convex slot at the top extrusion. **Be careful not to unscrew the bolts too far**, to avoid separating the double T-nut from the support.

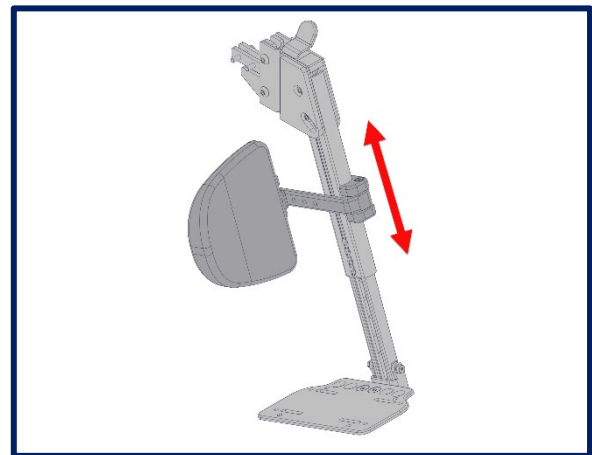

- d) Adjust calf pad to the desired height. Avoid choosing a height that will hide the holes on the bottom section of the legrest. Adjustment is infinite within a range of 4¼" (110 mm).

### Adjusting the new SIGNATURE front rigging (cont'd)

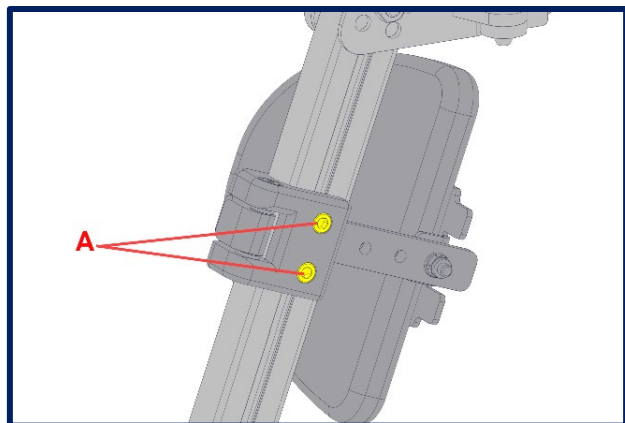

- e) Tighten both bolts (A) to secure calf pad to legrest.



- f) Re-insert bottom section into top section of legrest.

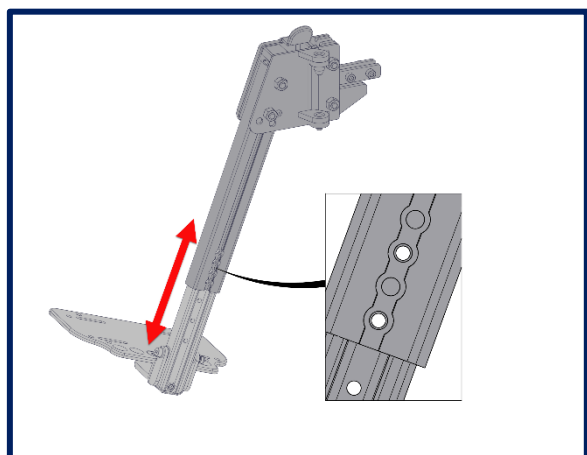

- g) Slide the lower part of the legrest to the desired height making sure to align the extrusion holes. Adjustment is made in  $\frac{1}{2}$ " (12.5 mm) increments according to the following ranges:  
 SOFLA12: 12 $\frac{1}{2}$ " - 17 $\frac{1}{2}$ " (320-445 mm)  
 SOFLA14: 14 $\frac{1}{2}$ " - 19 $\frac{1}{2}$ " (370-495 mm)

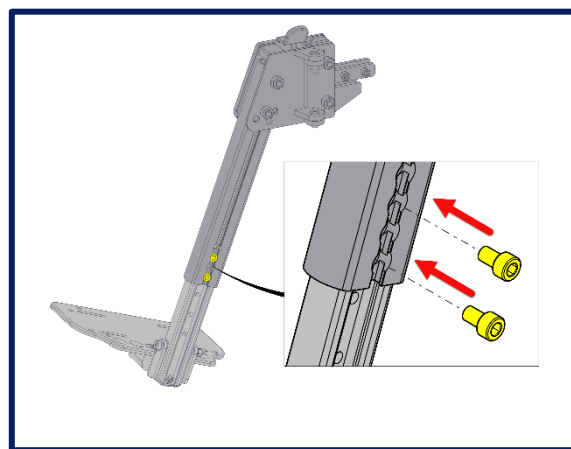

- h) Insert and tighten both bolts to secure the bottom section to the top of the legrest.

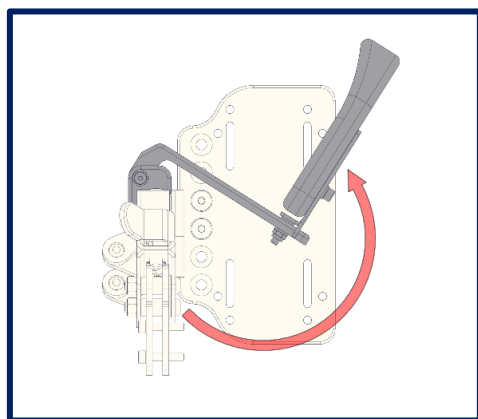

**NOTE:** The calf support is removable and can be rotated for better access some bolts. .

## Adjusting the new SIGNATURE front rigging (cont'd)

### 4.3. Calf pad depth adjustment

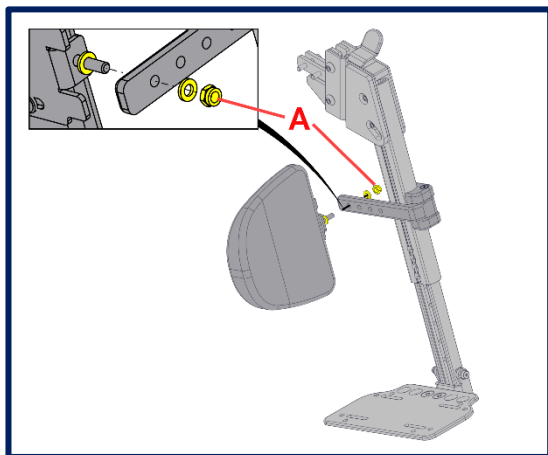

a) Using a 10 mm wrench, unscrew the nut (A) holding the calf pad to the bracket and remove the calf pad and its hardware.

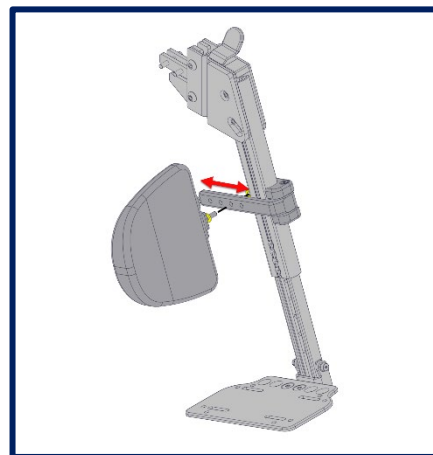

b) At the desired depth, put the calf pad back into the bracket while respecting the order of the hardware (see image a). Adjustment is at  $\frac{3}{4}$ " (20 mm) intervals within a range of  $2\frac{1}{4}$ " (60 mm).

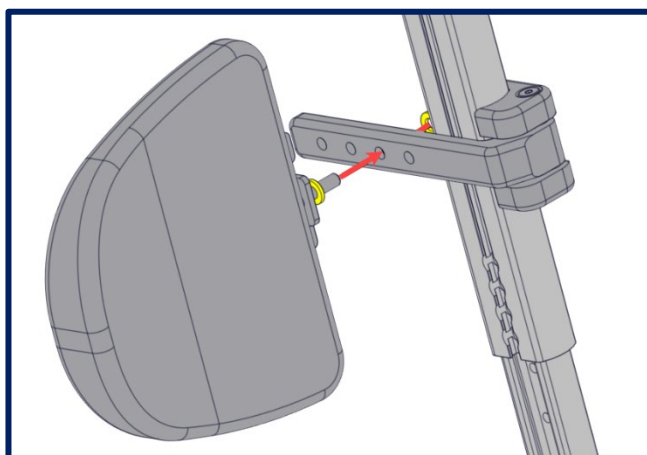

c) Tighten the calf pad bolt.

## Adjusting the new SIGNATURE front rigging (cont'd)

## 5. Adjusting Knee Angle

### 5.1. For Standard (STD) or Pediatric Legrests

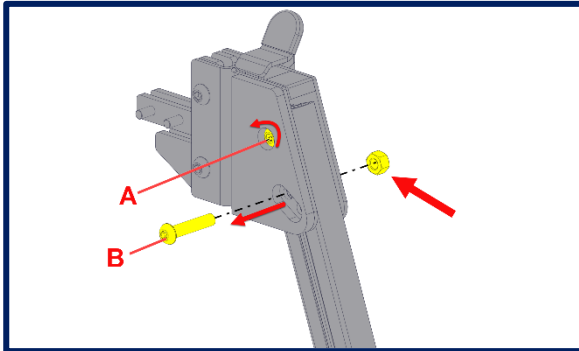

- a) Remove the plastic caps covering the nuts. Using a 5 mm Allen key and a 13 mm wrench, slightly loosen bolt (A) (**without removing it**) and unscrew bolt (B) without losing the nut on the other side.

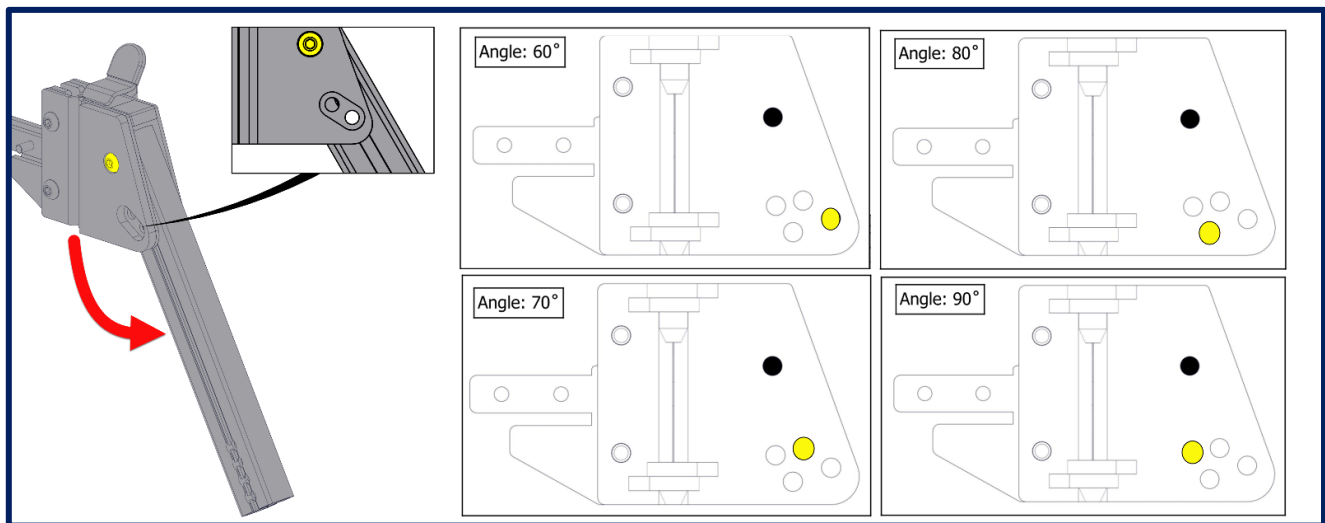

- b) Rotate the legrest extrusion to align its hole with the angle hole. See image above to select desired angle.

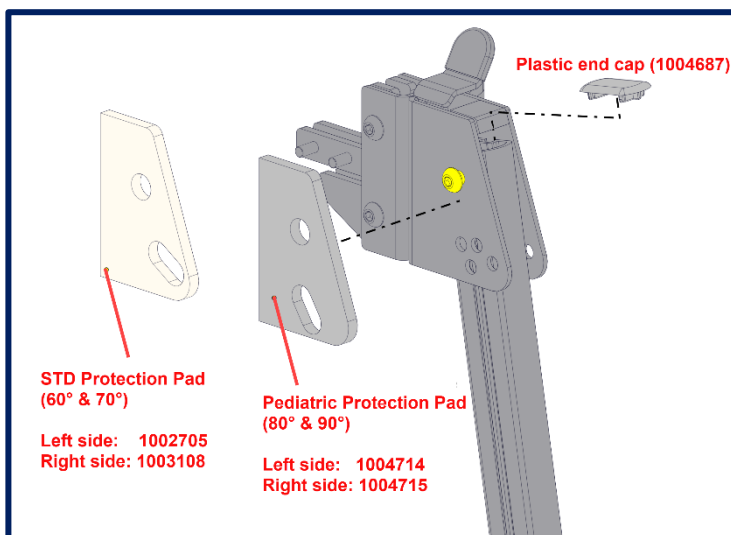

**NOTE –** For 80° or 90° angles on Pediatric legrests you must:

- Replace the STD padded protectors (1002505/1003108) with the Pediatric padded protectors (1004714/1004715).
- Add plastic end caps (1004687) at the top of legrests.

### Adjusting the new SIGNATURE front rigging (cont'd)

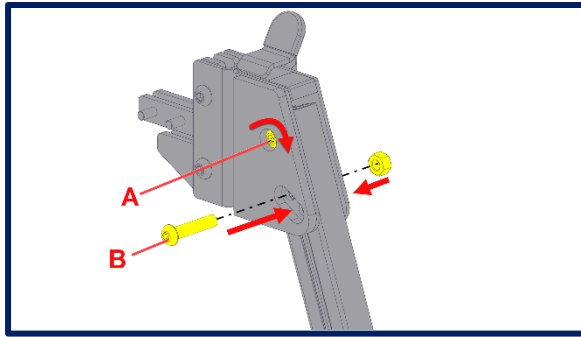

- c) Re-insert bolt (B) with nut and tighten bolt (A). Place plastic end caps to cover nuts.

#### 5.2. For Heavy-Duty (HD) Footrests, Manual & Power Elevating/Articulating Legrests

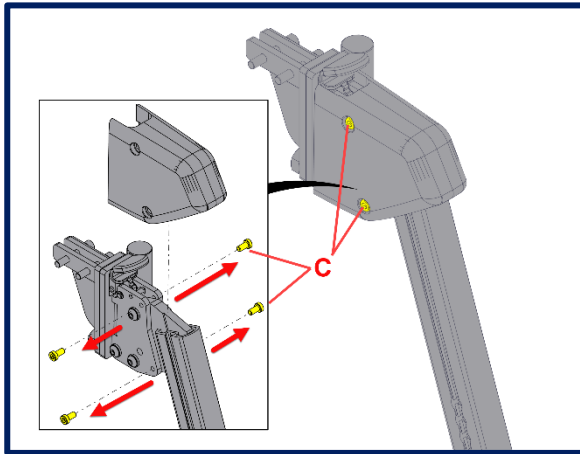

- a) Using a 3 mm Allen key, unscrew the four bolts on each side (C) and remove the protective cover to gain access to the angle adjustment bolts.

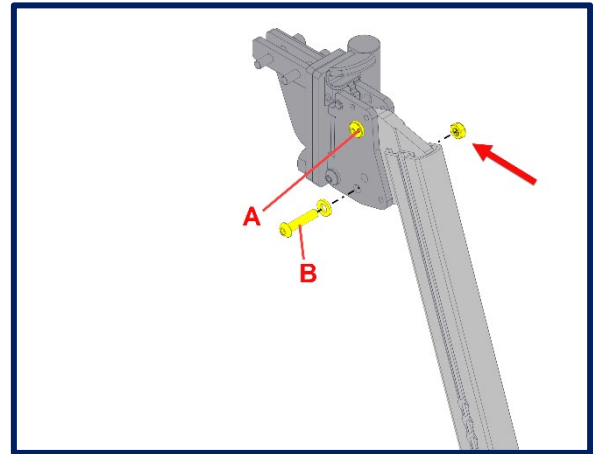

- b) Using a 4 mm Allen key and a 10 mm wrench, slightly loosen bolt (A) **without removing it**, and unscrew bolt (B) without losing the nut on the other side.

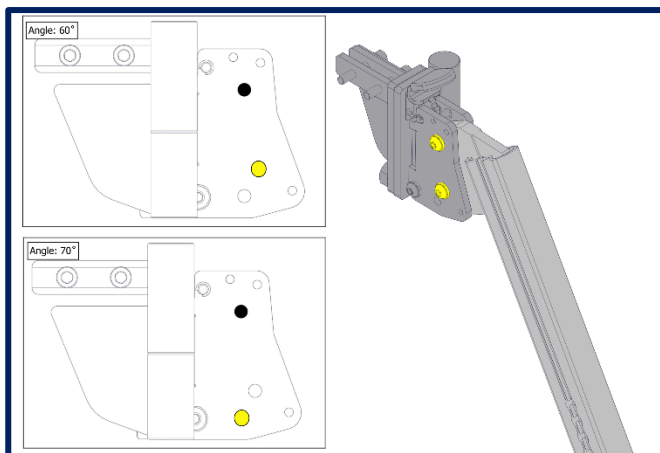

- c) Rotate the legrest extrusion to align its hole with the angle hole. See side image to select desired angle.

### Adjusting the new SIGNATURE front rigging (cont'd)

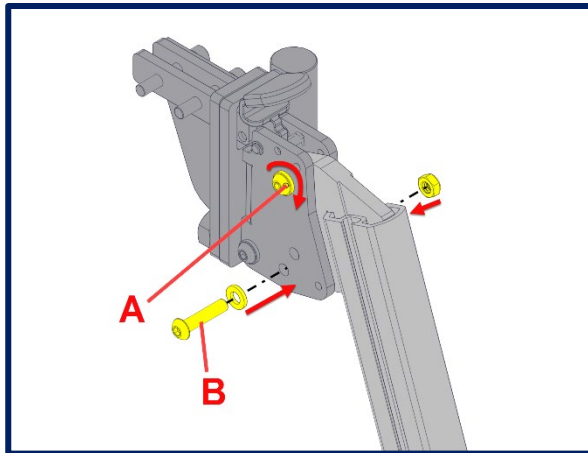

d) Re-insert bolt (B) with nut and tighten bolt (A).

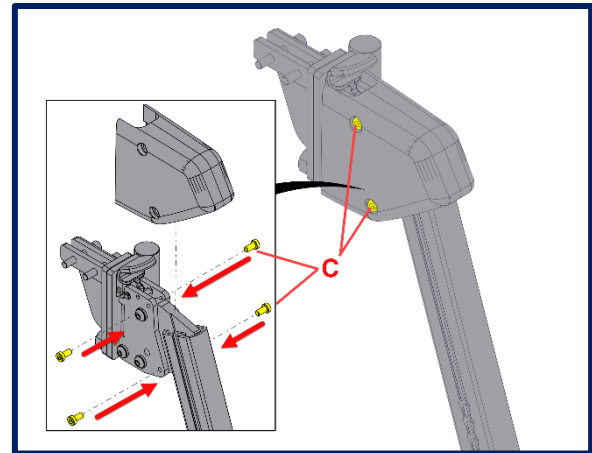

e) Place the protection cover back on, re-insert and tighten all 4 bolts (C) using a 3 mm Allen key.